



Uponor

Installation Guide for Underfloor Heating System

Technical information

Exclusively for Uponor installers – collect uPoints and get rewarded!



You have put your trust in us and our products. Now we would like to thank you – with our loyalty scheme, Uponor & more. Collect uPoints when buying selected Uponor products and exchange them for rewards.

It's so easy: www.uponor-more.co.uk



1. Register

Register to join the scheme and enjoy the many advantages of Uponor & more!



2. Collect uPoints

uPoint vouchers are enclosed in many key Uponor products. Just enter the unique voucher code number in the Uponor & more portal at www.uponor-more.co.uk and fill up your uPoint account.



3. Choose rewards

Now for the best part of the Uponor & more scheme. Once you have collected enough uPoints, simply exchange them for fantastic rewards! Enjoy!



Uponor uPoint voucher and rewards

Uponor voucher enclosed in many Uponor Products.



Introduction and Guarantee	4
Underfloor Heating Design Principles	5
Preparation and Installation Principles (prior to installation)	9
Installation instructions	13
- Manifolds	14
- Minitec System	16
- Solid Screed Floor	22
- Self Attaching System	25
- Timber Suspended Floor	30
- Siccus Floating Floor	31
- Tignum Wood Panel System	34
Water Temperature Control	41
- Push 12	42
- V5 Compact Control Pack	46
- VPG and PPG Control Sets	48
- Smatrix Move/Move PLUS Controller	51
Uponor Heating & Cooling Controls	57
- Smatrix Wave	59
- Smatrix Wave PLUS	61
- Smatrix Space	63
- Smatrix Base	64
- Base 230V	65
Mechanical & Electrical Schematics plus typical layout	67
Heat Pumps	81
Filling, Venting and Pressure Testing	83
Starting-up & System Operation	87
- Auto-Balance	90
- Trouble Shooting	92

Introduction and Guarantee

Underfloor heating (UFH) systems are not difficult to design or to install, but it is important that the guidelines and instructions are carefully followed to ensure that the system performs correctly once installed and has a long service life. This guide explains the fundamental principles and design of Uponor UFH and also gives installation guidelines for the components and systems.

Heating engineers familiar with installing conventional central heating systems will be accustomed to working with radiators, convectors and copper pipes.

Installing UFH is different, although the heat source is often the same, the materials and method of heat distribution are different.

1. There is a central distribution point, the manifold, which is served by the primary heating source and which distributes warm water to the pipes of the UFH system.
2. UFH operates with a low water temperature flow and return and therefore requires its own water temperature controls and own pump.
3. UFH uses the whole floor area as the heating medium, replacing radiators or convectors.

The use of Uponor pipe systems makes the installers physical task much easier. However, it is vital that the work is done correctly, as once the installation is complete and pipes are embedded in the floor, it would be difficult to make changes.

Responsibility

The overall efficiency of the system is inherent in its design. The installer is solely responsible to the client for ensuring that the design and system criteria are followed. The system must be installed in accordance with the design and with other recommendations contained within this guide.

This guide is not intended to override the skills of the individual installer; it is published simply as a guide to installing Uponor Underfloor Heating Systems and is based on methods and practices developed over many years. It is hoped that it will provide a useful background on installation for those who are not yet familiar with the system.

Words and pictures obviously cannot replace experience. The guide should be read through BEFORE attempting the first installation. It is the responsibility of the client to ensure that all relevant information is supplied and to ensure that any design work from Uponor is suitable for the particular purpose.

Uponor trained installers are available to install the UFH system. Technical support is available from Uponor to help with queries, if others are installing the system. However, it is important to note that the ultimate responsibility for the system operation rests with the installing company. Uponor Limited has a policy of continuous improvement and reserves the right to change any specification without notice.



Guarantee

Uponor Limited ("Uponor") guarantees [to the original purchaser/customer] that pipes and fittings sold by it are free of defects in materials or manufacture under normal conditions of use for a period of 25 years and in case of electrical and mechanical products for 2 year from the date of installation. This guarantee only applies to the products stored, installed, tested and operated in accordance with the fitting instructions issued by Uponor and valid at the time the products were installed.

Where a claim is made during the guarantee period and products are proven to be defective in materials and/or manufacture at the time of delivery, Uponor will supply replacement products free of charge. This is the exclusive remedy under this guarantee.

Uponor disclaims any warranty or guarantee not expressly provided for herein, including any implied warranties of merchantability or fitness for a particular purpose.

Uponor further disclaims any and all responsibility or liability for losses, damages and expenses, including special, direct, indirect, incidental and consequential damages, whether foreseeable or not, including without limitation any loss of time or use or any inconvenience arising from the ownership, installation or use of the products sold hereunder.

This guarantee does not affect the statutory rights of the consumer.

Underfloor Heating Design Principles

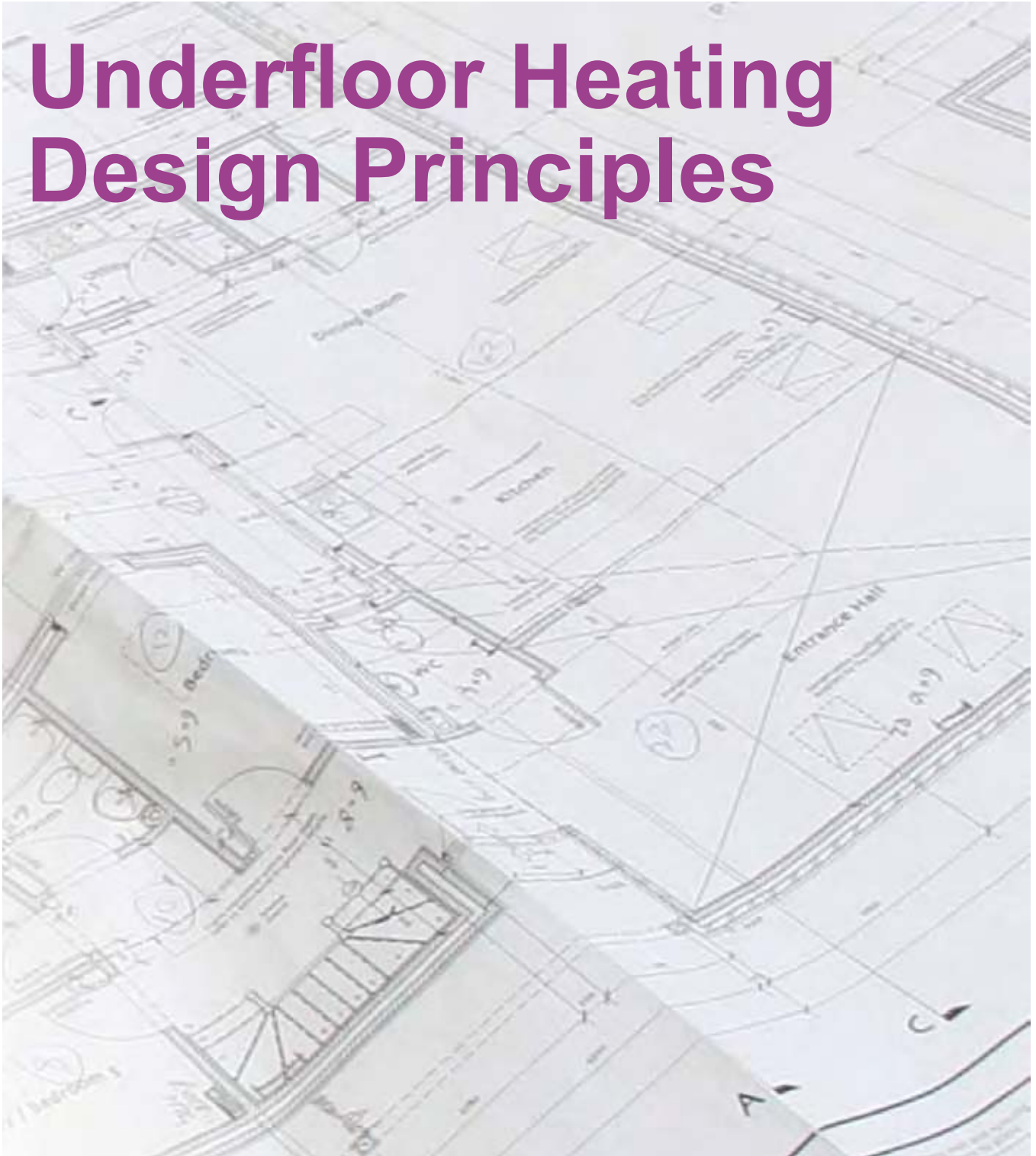

This section provides information about how the underfloor heating (UFH) system is designed and highlights points to consider before the design work commences.

Principles to consider	06	Insulation	08
Floor construction type	06	Floor coverings	08
Pipe spacing and layout	07		

Underfloor Heating Design Principles

Space Heating

Whatever the method used, the purpose of all space heating is to create an acceptable level of human comfort within a defined area. "Comfort" however, is a subjective concept. It will vary from person to person according to their age and activity level. There is therefore no universal ideal design temperature for all occasions - a sheltered housing project may require air temperatures of 21°C, while just 15°C may be adequate in a gymnasium or indoor sports hall.

Principles

The principle of UFH is very simple. Rather than mount metal panels on walls, pipes are laid in the floor and warm water circulated so that the floor effectively becomes a large radiator. Because the floor is so large compared to a normal wall-mounted radiator, it needs to run only a few degrees above the air temperature to provide enough warmth to gently heat the whole room. The primary aim of the floor heating design is to create an even, uniform surface temperature across the entire floor area within the building in order to ensure a consistent comfort level throughout the structure. When the floor temperature is higher than the air temperature, the floor will emit mainly radiant heat. The heat output from the floor is directly related to the temperature of the floor and that of the surrounding air. Loops of pipes are normally installed beneath the whole floor area. These loops are connected to a central manifold, which is supplied with hot water from a suitable heat source - such as a boiler or heat pump - heat pumps are becoming ever more popular due to the potential energy savings. Usually, with boilers as the heat source, the central heating water is mixed before it reaches the manifold to reduce the water temperature to that suitable for the UFH system. Controls reduce the water temperature to maintain the correct design temperature and pump the warm water through the UFH pipes.

Heating with UFH

UFH is a true radiant system and heats from floor to ceiling. UFH avoids wasted heat at high level and since the whole floor is heated evenly, optimum comfort is achieved everywhere in the room. In fact, the room thermostat can be set 1 – 2°C lower than a radiator system and the room will still feel more comfortable! Running the system at a lower temperature and reducing the heat wasted at levels above head height makes for significant savings on fuel costs. The exact savings that can be expected are difficult to determine, as there are operational factors that also need to be considered.

Heat Outputs

It is the clients responsibility to check that heat losses of the building, carried out by a heating consultant or engineer, are compatible with the outputs given. Generally, the maximum output from an UFH system is often stated at between 70 and 100 W/m². The actual output achieved is a direct relationship between the difference in floor surface and room air temperatures. The floor construction, floor covering

material, pipe size, pipe spacing, and the temperature of water circulating through the UFH pipes are major factors that determine the floor surface temperature. When designing conventional heating systems it is necessary to know the required heat output to be able to size the heat emitter. However, for UFH the size of the emitter is fixed - it is the floor area. Hence, the heat output is a function of the operating temperature of the floor, the floor area, and room air temperature.

Heat Requirements & Supplementary Heating

Given the low U-values stipulated in current Building Regulations, it is unusual to require outputs greater than 70W/m², based on a 20°C internal design temperature. It is important to note that poorly insulated buildings, conservatories, areas with high ceilings and rooms with high internal temperature requirements, may require supplementary heating during mid-winter conditions. The heating consultant or engineer should provide heat loss calculations. Heat losses are calculated in the conventional way and the boiler size will be similar whether UFH or other heating system is used. Uponor will specify maximum heat outputs for the floor and air temperatures specified. Providing the project complies with current building regulations, particularly with regard to thermal insulation levels, these outputs should be more than adequate to meet heat losses and provide full comfort conditions.

Design Limits

Establishing the correct operating temperature for the floor surface is a balance between not having the temperature so high that it causes discomfort, but high enough so that sufficient heat output is provided to meet the calculated heat losses. BS EN 1264-2 states that the 'physiologically agreed' maximum floor surface temperature is 9°C above the room temperature. This results in a maximum floor surface temperature of 29°C in typically occupied areas with a room temperature of 20°C. A 9°C temperature difference will equate to a floor heat output of 100W/m².

Floor Construction Type

Floor construction is another key factor in the design. Screed floors, suspended wooden floors and floating floors all require individual consideration to ensure optimum performance and an even distribution of heat across the surface of the floor. The screed or solid floor system relies on the conductivity of the screed or concrete to conduct the heat from the pipe surface to the underside of the floor finish. Because the screed is itself heated to conduct the heat it tends to store considerable amounts of heat and thus provides a slow response when both heating up and cooling down. Timber floor systems rely on the conductivity of components fitted within the floor to conduct the heat from the pipe to the underside of the floor finish. In order to achieve good results the pipes must transfer their heat evenly to the floor surface. Inadequate heat dissipation and hot spots can cause unsightly shrinkage, particularly with natural wood boards.

Because the mass of a timber floor structure is less than the mass of a screed floor, the system response of a timber floor system is usually much faster. The floating floor system is predominantly suitable for sheet flooring or some stronger laminates. The grooved insulation is structural and laid on top of a prepared base. Additional insulation may be required to ensure compliance with Building Regulations and to minimize downward losses.

Water Temperature Control

To meet the requirements of BS EN 1264, water temperature control must be provided. This ensures that maximum floor surface temperatures are not exceeded. All Uponor water temperature controls are designed to mix and control the primary heat source flow water temperature with the UFH return water temperature, to a temperature suitable for the UFH system.

Boiler/Heat Source

Traditionally, the primary heat source has been a boiler, producing low temperature hot water for the system. Modern high efficiency condensing boilers are ideal for UFH as the low water temperatures allow the boiler to work in condensing mode. If the heat source is able to provide and maintain a constant or variable water temperature at the requirement for the UFH, it may not be necessary to have any further water temperature controls. If there are no services, other than the UFH, being supplied by the boiler and water temperature controls are used, it may be necessary to have a heat sink, such as a towel rail, prior to the UFH mixing valve to prevent the boiler from cycling and cutting out on high limit. However, ultimately, careful thought must be given when choosing your boiler, as not all units are compatible. Always check the specific application with the boiler manufacturer. More recently, other sources have become available which are ideal for UFH such as ground source or air source heat pumps.

Calculating Size of UFH Pump

The smooth inner surface of MLC and PEX pipes reduces the pressure loss, optimising the pipe length that can be used. The temperature drop across the pipe loop and the maximum required heat emission determines the water flow rate required through the pump. The Uponor V5 Compact Control Pack and pre-assembled VPG and PPG are supplied complete with a suitably sized UFH circulating pump.

Pipe Spacing

In solid screed floors and areas of average to low heat loss, Uponor will generally recommend standard pipe spacings of 300mm (20mm diameter pipe) or 200mm (16mm diameter pipe). In areas of high heat loss, the pipe spacing may be reduced to a minimum of ½ the standard spacing to achieve higher heat output. Such areas include: highly glazed areas such as a conservatory, rooms with high ceilings, bathrooms with limited floor area and poorly insulated buildings. Tighter pipe spacings can also be used within a peripheral zone, which is an area of floor between an external wall and 1 metre in from the external wall. Pipe spacings may be reduced when renewable energy heat source, such as a ground or air source heat pump, is employed. In this

instance, tighter pipe spacings will allow for lower hot water temperatures and result in improved efficiency and lower energy costs. Ensure that there is sufficient pipe length available prior to installing at reduced pipe centres.

Timber suspended and floating floor pipe spacings tend to be fixed by the particular system and the UFH components used. In order to calculate the amount of pipe required, the following guide can be used:

Pipe Spacing (mm)	Quantity of pipe (m/m ²)
300	3.4
200	5.0
150	6.7
125	8.0
100	10.0
50	20.0

Important Note:

When calculating your pipe requirement, remember to add the feed/tail pipe lengths, between manifold and room, to your calculations.

Pipe Layout

Where possible, the pipe should be laid so that the flow direction is to the coldest area of the room first, e.g. under windows, along outside walls. There are typically two patterns for installation in solid floors, the meander/serpentine pattern (1), or the bifilar/snail pattern (2). With the meander pattern the flow pipe is first directed towards the window or cold part of the room before returning backwards and forwards across the room at the defined spacing. The bifilar pattern is where the flow pipe is run at ever diminishing circles until it reaches the centre of the floor area, then it reverses direction and returns parallel to the flow pipe back to the starting point. Both patterns of installation are acceptable, however the meander pattern is often used against areas of high heat loss, while the bifilar pattern is employed where even floor surface temperature is required.



Meander pattern (1)



Bifilar pattern (2)

Pipe Bend Radius

The minimum manual bend radius for Uponor pipe is:



Pipe	min. Bend Radius
9.9mm PEX	50mm
12mm PEX	60mm
16mm PEX	80mm
16mm MLC	80mm
20mm PEX	100mm

On tight pipe spacing, allow the pipe to 'balloon' at the 180° turns.

Screed Floors

For solid floor construction, a normal sand/cement floor screed can be used. No special additives in the screed are required. Where the pipe is laid on insulation, the minimum screed depth must be 65mm for domestic applications and 75mm for commercial applications as specified in British Standards. Uponor recommends that the optimum screed thickness is 75mm but no more than 90mm, for most applications. Where heavier floor loadings are required, the construction engineer should advise on the screed thickness. Specialist flow/liquid Screeds, when used with underfloor heating, must provide a minimum 30mm coverage over a pipe or conduit. The Minitec system can be used with an approved self-levelling compound installed over a stable and sturdy floor substrate with minimum 15mm build height. Careful consideration must be given to the expansion of heated screed floors. As a guide when using semi-dry cement and sand screeds, BS EN1264 - Part 4 recommends a maximum screed area of 40m² can be laid without expansion allowances. With Anhydrite screeds much greater areas can be laid without expansion joints; e.g. in Sports Halls up to 600m². When using an Anhydrite screed always check with the supplier for their requirements.

The screed must be allowed to dry and cure normally, in accordance with the relevant BS Standards and manufacturer and supplier instructions, before initial heating and system start-up. The underfloor heating MUST NOT be used to speed up the curing process.

Timber Floors

There are many types of wood flooring which are considered suitable for use with UFH and, equally, there are several methods of installing timber, which also must be taken into consideration before the system is designed. Particular attention must be paid to the moisture content of wooden floors. Not all timber floors are suitable for UFH and advice should be sought from the flooring supplier or from the trade association TRADA.

Insulation

A layer of insulation should be applied beneath the circuit pipework to prevent downward heat loss, thus maximising the heat output into the room. It is also important to provide edge insulation around the perimeter of the area where UFH is installed, especially on screed floors, to avoid heat transfer/losses into the vertical structure. It also allows for an amount of expansion of the slab.

Exposed Ground Floors:

Exposed ground floors should be thermally insulated to latest requirements of Building Regulations Part L (England & Wales) and in addition, for UFH systems, should limit downward heat losses to no more than 10W/m². Supplementary insulation, above the normal Part L requirements, may be required if floor coverings with high thermal resistance are used. If insulation is already fitted below the concrete slab, a recommended minimum insulation thermal resistance of 1.25m²K/W should be installed above the slab (equivalent to Uponor 50mm Rolltec insulation boards), to improve the UFH system response times.

Intermediate Floors:

Intermediate floors, with heated rooms below, should have a separating layer of insulation having a minimum 0.75m²K/W thermal resistance (equivalent to Uponor 30mm Self Attaching System Roll insulation), to comply with BS EN 1264-4. All floor constructions should be compliant with Building Regulations, including Part E and Part L (England & Wales). It is the responsibility of the architect and/or the builder to ensure that the insulation is adequate for the requirements of the underfloor heating and Building Regulations.

The relevant Building Standard codes for other countries are:

Northern Ireland - Technical Booklets F (Conservation of Fuel and Energy) and G (Sound).

Republic of Ireland - Parts L (Conservation of Fuel and Energy) and E (Sound)

Scotland - Sections 6 (Energy) & 5 (Sound).

Protective Layer

It is essential to prevent screed from slipping between the insulation board joints, creating a cold bridge and to inhibit the migration of water during the construction process. This is normally achieved by taping the joints of Uponor supplied insulation, such as, PUR board, Multifoil and Rolltec or alternative foil faced insulating boards, which have the protective layer incorporated within. Alternatively if using an insulation without a protective layer, use a polythene film of at least 0.15mm thickness over the insulation, prior to laying the floor screed. If using a liquid screed (calcium sulphate), please consult the screed specialist for confirmation of suitable layers to be used above the insulation.

Floor Coverings

Most floor coverings can be laid on UFH systems. The floor covering supplier should be consulted to ensure that any special recommendations are followed, e.g. maximum temperature limits, wood drying conditions, special glues, etc. It is strongly recommended that before any coverings are laid on screeded systems, the UFH system is run for two weeks (after normal screed drying time) and allowed to cool. In all cases, it is recommended that thick felts, thick underlays, and cork are avoided. For optimum performance Uponor advise that a maximum combined thermal resistance, for floor coverings, of 0.15m²K/W is not exceeded, in accordance with the British Standard BS EN 1264, which equates to a carpet and underlay TOG value of 1.5. However, recent independent testing has shown that against current Building Regulations and reduced heat losses, a combined carpet and underlay TOG value of 2.5 is acceptable when used above a screed floor, although the underlay used should not exceed 1 TOG and must be suitable for use with UFH. We advise, where possible, to have masonry coverings, - e.g. ceramic floor tiles, slate, stone, marble etc - as this offers little thermal resistance and reduces downward heat losses. After the floor covering has been laid, the UFH system can be "tuned" to match the variations in floor coverings in each room by adjusting the manifold loop flowrates.

Preparation and Installation Principles



Providing the installer with key elements to check prior to installation and ensuring the project runs smoothly.

Before installing	10	Connection to primary circuit	10
First time tips	10	Floor types and tools required	11

Preparation and Installation Principles

Before Installing

Prior to installation, it is important that the installer makes the following checks to ensure the project runs as smoothly as possible:

1. All the materials and the quantities are correct and on site against the delivery note and against the material schedule.
2. All other trades involved in the installation are fully conversant with component layout and positioning. For example, for first fix wiring, the electrician should know the positions of the room thermostats, water temperature controls, time clocks, etc (see Chapter 6 for further details).
3. Sub-floors are clean, level and are correct for the depth of construction needed to incorporate the underfloor heating.
4. Ensure all other trades not involved with the installation are notified and excluded from the installation area before and during installation.

It is important to read in full and understand all installation instructions offered before commencing installation.

First Time Tips

- For first time installers, laying the pipe needs two people; one person holding the pipe coil and un-rolling it, with the second person, a couple of metres behind, securing the pipe in position. For ease of clipping pipe into insulation we would advise investing in a Kombi tacker gun (1002295).
- Only one person is needed if using a pipe de-coiler. Place the de-coiler in another room and pull the pipe off as required. (PEX only)
- Check which water temperature controls are to be used and where they are to be positioned to ensure that enough room is allowed for the manifold.
- Check the position of the manifold and fit the manifold before laying the pipe work.
- Ensure that the pipe does not become twisted when handling as it can become awkward to install. The pipe will twist slightly on bends but the print line is a good guide to assist in laying the pipe.
- During cold conditions, installation and handling will be easier if the pipes are stored overnight in a heated room before installing.
- To avoid kinks always pull the pipe to shape rather than bend and try and force into position.
- If the pipe does become kinked, the kink can be removed using one of these two methods, depending on which system is being installed:
 - 1.If using MLC pipe, gently squeeze the kink/crease with soft pliers and reform the bend away from the kink.
 - 2.If using PEX pipe, gently heat the kink/crease with a warm air gun (NEVER a naked flame) until the pipe is hand warm, max 130°C.

Contact Uponor for further technical advice if necessary.

- Always cut the pipe square and use a plastic pipe cutter ensuring that there are no burrs on the pipe ends. It is important to achieve a clean cut at right angles to the pipe.
- For solid floor, allow a minimum distance between pipe and wall face of 100mm.

Connection to Primary Circuit

Each manifold and/or water temperature control station must be served by a flow and return from the central heating source and primary heating circuit. Where the heat source is providing water at the correct temperature for the UFH system, the manifold can be connected directly onto the primary pipework.

When using either the V5 Compact Control Pack or the pre-assembled VPG or PPG pump group and a single manifold, connections can be made directly onto the manifold. Alternatively, when using the pre-assembled VPG/PPG pump group or un-assembled mixing valve arrangement, located away from the manifold position, a mixed flow and return supply is required between the manifolds and controls, sized in accordance with the required flow rate and pressure drop.

Unless otherwise specified or requested, Uponor does not design or supply the primary supply pipe work.

As a precaution and in accordance with good practise Uponor recommends that a by-pass is always fitted in the primary pipework.

Floor types and recommended tools

Floor	Screed	Timber Suspended - Heat Emission Plates	Siccus Floating Floor	Tignum Tracked wood	Minitec System with Self-Levelling Compound
9.9mm PEX - Minitec	✓				✓
12mm PEX			✓	✓	
16mm PEX	✓	✓	✓		
16mm MLC	✓	✓	✓		
20mm PEX	✓	✓	✓		
Tools required					
Uponor plastic pipe cutter	Yes	Yes	Yes	Yes	Yes
Drill and necessary drill bits	Yes	Yes	Yes	Yes	Yes
Suitable wall fixings (for manifold)	Yes	Yes	Yes	Yes	Yes
Plumbers wrench/grips	Yes	Yes	Yes	Yes	Yes
Kombi Tacker Gun	Yes				
Hammer		Yes	Yes	Yes	
Sharp wood saw		Yes			
Chisel		Yes		Yes	
Hacksaw		Yes	Yes		
Stanley knife		Yes	Yes		Yes
Staple gun or tacks		Yes			
Insertion depth tool (for MLC pipe only)	Yes	Yes	Yes		
5mm Allen key (for LS manifold only)	Yes	Yes	Yes	Yes	Yes
Uponor polysterene hot cutter			Yes		
Circular saw or similar				Yes	
Vacuum cleaner	Yes	Yes	Yes	Yes	Yes
Tape measure	Yes	Yes	Yes	Yes	Yes
Pipe expander tool and head	Only required when Q&E PEX fittings are used				

Uponor Minitec

Radiant Heating and Cooling



Minitec panel height



Your advantages

- 15mm overall build height
- Fast and easy to install
- Bonds directly to subfloor
- Ensures total pipe encapsulation
- Suitable for total floor area coverage
- New build and renovation projects
- Rapid heat-up times
- Uponor Minitec goes with different covering layers – depending on individual needs
- Suitable for installation on multiple floor constructions
 - New or existing concrete/screed floors
 - New or existing timber floors
 - Existing tile floors
- High thermal comfort level
- Output -> 100w/m²
- Ideal partner for renewable technologies



This section will help you select the most appropriate system for your needs and take you through each stage of the installation.

Vario B flowmeter and lockshield valved manifold	14	Timber suspended floor	30
Minitec	16	Siccus floating floor system	31
Solid screed floor	22	Tignum chipboard panel system	34
Uponor Klett (Self Attaching System)	25		

Installation instructions - Vario B Flowmeter and Valved Manifolds

Pipe Dimensions	9.9mm PEX	✓	12mm PEX	✓	16mm PEX	✓	16mm MLC	✓	20mm PEX	✓
-----------------	-----------	---	----------	---	----------	---	----------	---	----------	---

The Uponor Manifold is made from a high quality brass with a chromed finished and is for the distribution of hot and cold water in the area of radiant heating and cooling systems. The pipe loops are secured to these manifolds by the compression adaptors (supplied separately). Manifolds are supplied in pairs, i.e. a flow and return manifold, together with fixing brackets. Manifold sets are available with between 2–12 outlets with a single loop extension set also available.

Location

Manifold locations need to be positioned strategically and as central as possible, in order to reduce the amount and length of pipe tails and uncontrolled energy from pipes passing through heated areas en-route to other rooms/areas. It is important to select the manifold position at the beginning of the design process. If you have received a design and quotation from Uponor, manifold locations will be specified on the quotation.

Ensure there is sufficient height available, from the floor level to the lower return manifold, to enable easy connection of the UFH pipework (minimum 300mm). Although it is not necessary to have the manifold on show, it should be accessible for maintenance and servicing. Typical locations include; understairs cupboard, utility rooms, airing cupboards and cloaks cupboards.

Vario B Manifold with Flowmeters

The supply section (top) offers shut off and flow rate control features, via the $\frac{1}{2}$ " meter on individual loops. The $\frac{1}{2}$ " meter is designed to provide the setting and visual indication (0-6 l/m) of each UFH loop flow rate, by adjustment of the meter. The red locking ring can be snapped over the $\frac{1}{2}$ " meter to stop any unwanted changes made to the flow rate after commissioning has taken place.

Vario B Manifold with Lockshield Valves

The supply section (top) offers shut off and flow rate control features, via the lockshield valve on each individual loop. A 5mm Allen Key is required to set each valve.

Return Manifold

The return section (bottom) offers valves, including blue caps, for manual loop isolation. Caps can be replaced by electric thermal actuators for the provision of automatic room temperature control to individual loops. A suitable Uponor control system will be required to drive the thermal actuators.

Fixing Brackets

Fixing brackets are supplied with the manifold. The brackets should be positioned on the wall and then the manifold secured in position. The lower manifold is staggered further out from the wall to allow the pipes from the upper manifold to pass behind.

If using the VPG or PPG control assembly directly onto the manifold, additional packers are supplied, which are required behind the manifold brackets.

If using a V5 Compact Control Pack, this can be assembled onto the manifold prior to fixing on the wall or alternatively the Control Pack can be purchased pre-assembled and fitted to the Uponor Vario B Flowmeter manifold.

Fill & Drain Points

$\frac{1}{2}$ " Fill & drain points are supplied with the manifold along with $\frac{1}{2}$ "FT x 1" MT couplers. Fit the couplers to the flow and return manifold headers and then screw the fill and drain points to the spare connections on the couplers .

Connecting to the manifold

When laying the UFH loops, the first pipe end should be connected to the manifold before the loop is laid. Push the pipe-end lying on the outer side of the coil through and behind the return manifold and connect as per instructions below depending on which pipe is being installed. If insulating the feed pipes with Uponor conduit, we advise sliding this over the UFH pipe prior to connecting onto the manifold.



Uponor TM manifold with flowmeter, 2–12-way

- Uponor system components are mutually compatible and fully tested.
- Range of applications
- Maximum operating temperature 70°C
- Maximum operating pressure 6 bar
- Maximum water flow rate per manifold (12-way) 3.0 m³/h

Connecting Uponor MLC Pipes

Before pushing the pipe behind the manifold, carefully bend the pipe to prevent it being damaged.

- 1 Line the pipe end up to the threaded port on the manifold.
- 2 Then cut the pipe end square using plastic pipe cutters.
- 3 Measure 10mm from the top of the pipe and mark the insertion depth.



- 4 Hand-tighten the compression adaptor fitting onto the manifold outlet thread as shown.
- 5 Insert the pipe into the adaptor fitting and push until the pipe comes to a halt as shown (the insertion indicator should no longer be visible).
- 6 Now tighten the adaptor fitting onto the manifold, using an appropriate spanner, until the insertion depth mark can be seen again below the nut. (pic 7)

Connecting Uponor PEX Pipes

- Ensure a pipe bend support is fitted where the pipe exits the floor and turns up to the manifold. Line the pipe end up with the threaded port on the manifold and cut the pipe end square using plastic pipe cutters.

- Push the nut and olive onto the end of the pipe. Then push the insert fully into the pipe end in order to get a secure joint.
- Slide both the ring and nut onto the manifold port. Tighten the nut by hand.
- Then tighten a further one and half turns with a spanner.



Loop connections

Make loop connections with 3/4" male-threaded Eurocone in accordance with DIN V 3838 compatible with Uponor MLC & PEX pipe adaptors.

Observe the torque settings!

12 - 16mm: 50 Nm
20mm: 60 Nm

Additional manifold items

- Automatic air vent with thermometer gauge (item no 1046886)
- Automatic manifold by-pass (item no 1048278)
- Flowmetre manifold one loop extension (1002197)
- Lockshield valved manifold one loop extension (1002181)

Note: The Uponor Manifold can be extended by one loop with the connection of an individual loop set.

Room Labels

Room labels are supplied with the manifold to identify the room being supplied, together with loop flow rate/settings.

Loop control at the flowmeter

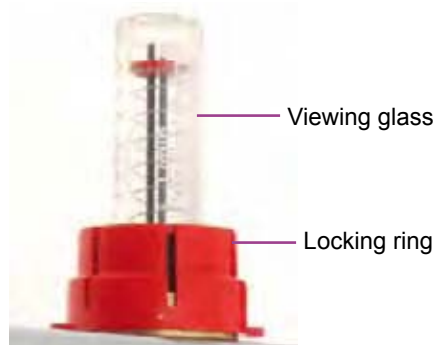

Installation instructions - The Uponor Minitec product line

Pipe Dimensions	9.9mm PEX	✓	12mm PEX		16mm PEX		16mm MLC		20mm PEX	
-----------------	-----------	---	----------	--	----------	--	----------	--	----------	--

Minitec benefits

- 15mm overall build height
- Fast and Easy to install
- Bonds directly to subfloor
- Rapid heat up times
- New build and renovation projects
- Suitable for installation on most existing floors; concrete, screed, timber and tiles.
- Ideal partner for renewable technologies

PEX-a 9.9 x 1.1mm UFH pipe

- 25 year manufacturing defect warranty
- Design life in excess of 50 years in accordance with DIN 16892
- Design pressure of 8bar at 70°C
- Available in 60, 120, 240 & 480m coil lengths
- Oxygen diffusion barrier conforming to DIN 4726
- Manufactured to ISO 9001 & 14001
- Conforms to EN ISO 15875

Minitec Panel

- Panel size: 1120 x 720mm
- Total panel height: 12mm
- Pipe spacings: 50, 100 & 150mm
- Can accommodate 45° & 95° angles

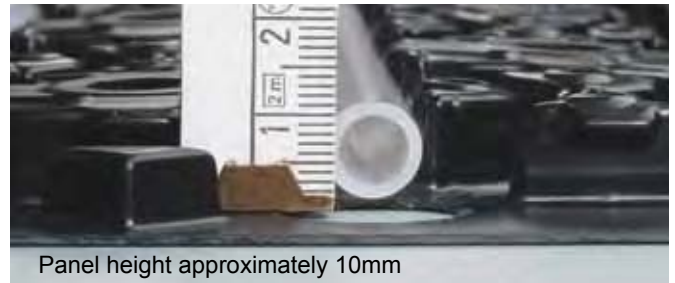

Panel height approximately 10mm

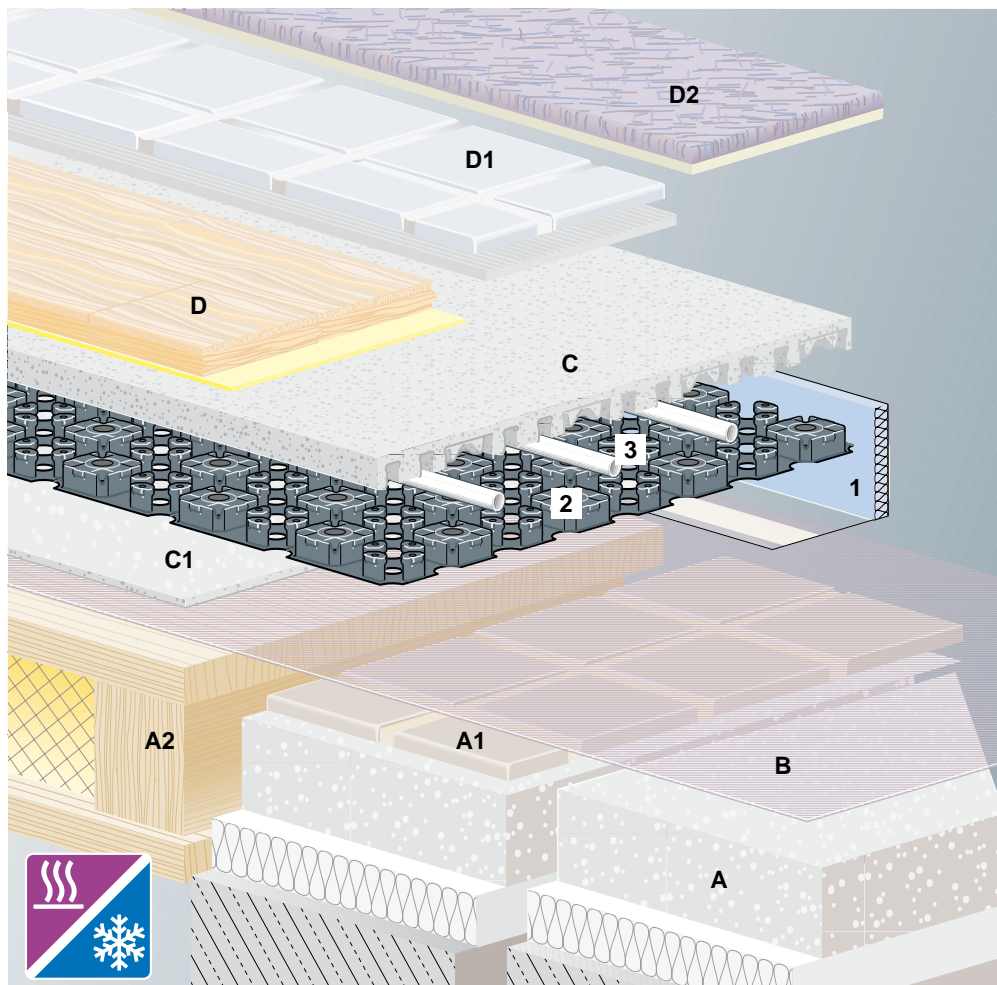

- 1 Uponor Edge insulation strip
 - 2 Uponor Minitec Panel
 - 3 Uponor PE-Xa 9.9 x 1.1 mm pipe
- A Existing screed with underlying thermal and sound insulation
- A1 Tiled floor
- A2 Timber joist floor
- B Priming of prepared substrate
- C Self-levelling compound
- C1 Additional levelling layer for timber joist floors
- D Parquet/laminate floor with additional separating layer or adhesive
- D1 Tiles with tile adhesive and grout
- D2 Carpet with carpet adhesive



7F 170 -F
PE-Xa 9.9x1.1

Minitec components



Uponor Minitec panel

The sturdy Minitec panel can be walked on instantly and ensures fast and efficient installation of the Uponor PE-Xa pipes by a single installer.

They are suitable for all room geometries and do not need to be installed right to the edge of the floor.



Uponor PE-Xa pipe

The flexible Uponor PE-Xa pipes 9.9 x 1.1 mm are placed in the prepared grooves of the Uponor Minitec panels. They are held in place by the castellations of the panel, ensuring that the installation meets the relevant standards. The panel is equipped with specially designed castellations for the laying of the pipe in 90° and also in 45° bends.



Uponor edge insulation strip

The self-adhesive edging strip with self-adhesive panel is available in L and I profile allows for a proper seal along the walls and the bottom.

In the first installation step, the edging strip should be glued to the bottom. Then, the Minitec panel on it should be glued along the edge.



Uponor movement joint profile

The Uponor Minitec product line contains all components for a proper mounting in doorways and for creating joint profiles for the design shape of individual covering layers.

Design basics

Temperatures

Floor surface temperature

Special attention must be paid to the floor surface temperature, taking into account medical and physiological considerations.

The difference between the mean surface temperature of the floor and the design indoor temperature, together with the basic characteristic, form the basis on which the capacity of the heating floor surface is calculated. The maximum surface temperatures are determined by the limit heat flow density defined in BS EN 1264, which is taken into account as the theoretical design limit in the design tables and diagrams.

Room temperature, perceived temperature and mean radiation temperature.

With radiant heating systems such as the Uponor underfloor heating systems, one can expect significant energy savings compared with less efficient heating systems.

This energy efficiency is mainly due to a better adjusted room temperature and the optimal vertical temperature profile in the room. To feel comfortable, the room air temperature ϑ_L as well as the mean radiation temperature ϑ_s of the surfaces enclosing the room are relevant factors. They result in a so called perceived operative temperature. That means that people, living in rooms with underfloor heating, feel more comfortable even when the room air temperature is reduced.

Max. surface temperatures according to BS EN 1264:

- 29 °C in comfort zone
- 35 °C in edge zone
- 33 °C in comfort zone

Standard design room temperatures:

Living rooms	21 °C	Bedrooms	18-21 °C
Corridors	18 °C	Bathrooms	24 °C

Pipe specification: 9.9mm O/D PEX - MINITEC
 Floor construction: Solid floor
 Screed depth: 15mm Self-Levelling Compound
 Screed thermal conductivity: 1.0 W/mK
 Water temperature drop [K]: 10

	Suitable for occupied zone
	Suitable for perimeter zone only

Mean water temperature MWT °C	Design room temperature Rt °C	Pipe pitch, Vz [mm]								
		50			100			150		
		Floor covering resistance, R _{λ,B} [m² K/W]								
		0.05	0.1	0.15	0.05	0.1	0.15	0.05	0.1	0.15
		W/m²	W/m²	W/m²	W/m²	W/m²	W/m²	W/m²	W/m²	W/m²
30	16	82	63	52	71	56	46	61	50	42
	18	69	53	44	60	47	39	52	42	35
	20	56	43	35	48	38	32	42	34	28
	22	42	32	27	36	28	24	31	25	21
	24	26	20	16	22	17	14	19	16	13
35	16	114	87	72	98	77	64	85	69	58
	18	102	78	64	87	70	57	76	61	52
	20	90	68	56	76	60	50	66	54	45
	22	76	59	48	65	51	42	57	46	39
	24	63	48	40	54	43	35	47	38	32
40	16	146	111	92	125	99	90	108	88	74
	18	133	102	84	114	90	75	99	80	68
	20	121	92	76	104	82	68	90	73	61
	22	108	83	68	93	73	61	80	65	55
	24	95	73	60	82	65	54	71	57	48
Maximum heat Output for Comfort Zone, q _H [W/m²]		95	95	96	85	87	90	76	80	85

Installation

General

Uponor Minitec must be installed by competent Installers. Observe the following assembly instructions and additional instructions which are provided with the components and tools or which can be downloaded from www.uponor.co.uk

Overview of the installation steps

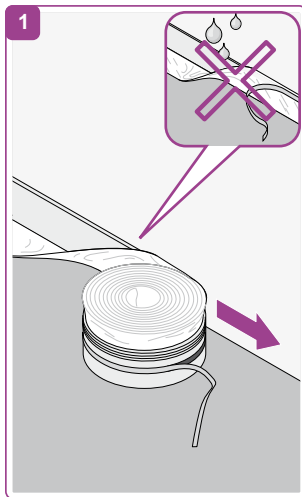

Mounting edge strips

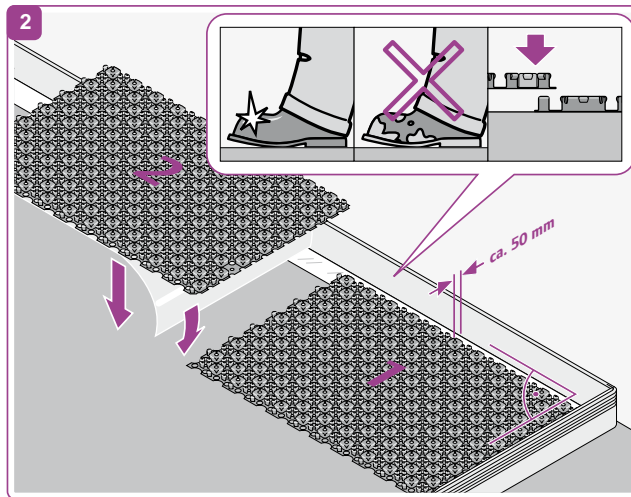

Installing Minitec panel

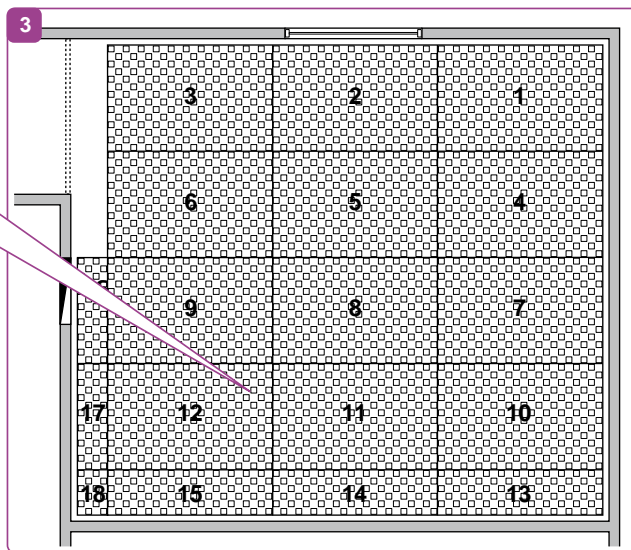
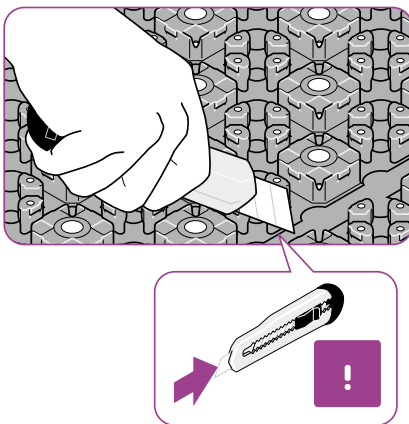

Installation steps for Minitec panel

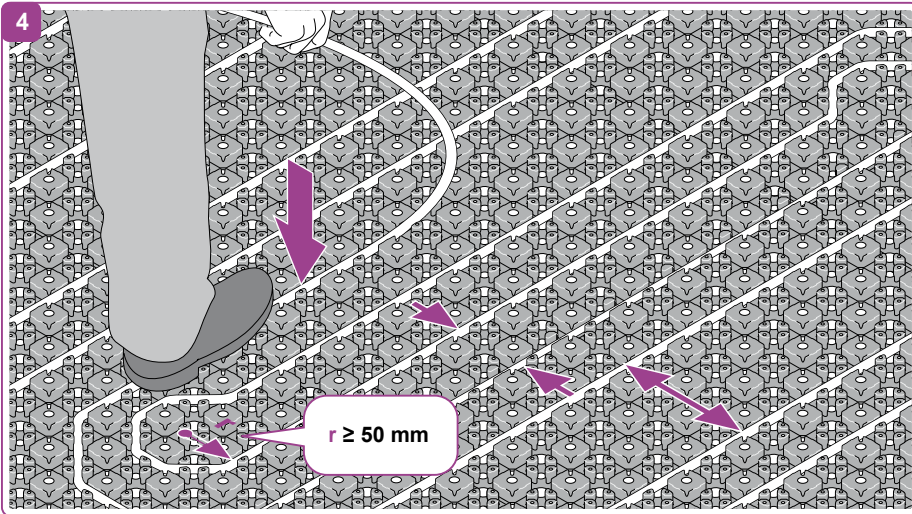

Installing pipes in Minitec panel

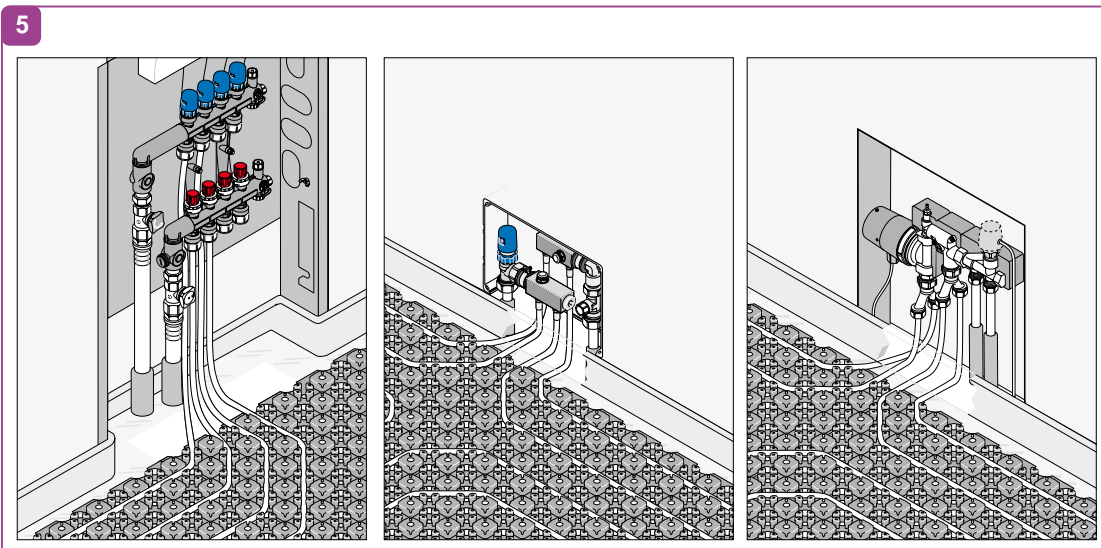

Connecting PE-Xa pipes

**Get to know more about
Uponor Minitec**

This QR code leads you to
the film:



Technical data

Uponor Minitec panel			
Material	Polystyrene		
Max. traffic load (including levelling compound)	5,0 kN/m ²		
Pipe spacing	Vz 5, 10, 15		
Panel dimensions (l x w)	1,120 mm x 720 mm		
Total element height	12 mm		
System type	Wet system*		
Volumetric share of levelling layer (at layer thickness 15 mm)	Vz 5 approx. 12.4 l/m ²	Vz 10 approx. 13.2 l/m ²	Vz 15 approx. 13.5 l/m ²
DIN reg. no.	7F170-F		

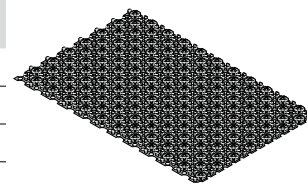

* on existing load distribution layer

Uponor PE-Xa pipe	
Pipe dimensions	9.9 x 1.1 mm
SDR (Standard Dimension Ratio)	Value 9 (acc. EN ISO 15875)
S (Pipe Series)	Value 4 (acc. EN ISO 15875)
Material	PE-Xa (acc. EN 16892)
Colour	Nature
Manufactured	According to DIN EN 16892 / DIN EN ISO 15875-2
Oxygen tightness	According to DIN 4726, section 3.5
Density	0.94 g/cm ³ (acc. EN 16892)
Thermal conductivity	0.35 W/mK
Mean thermal linear expansion coefficient at	70 °C: 0.15 mm/m K (acc. EN 16892)
Crystallite melting temperature	133 °C
Building material class	B2
Min. bending radius	50 mm
Pipe roughness	0.007 mm
Water content	0.0465 l/m
Pipe marking	[length] m PE-Xa 9.9 x1.1 oxygen-tight according to DIN 4726 EN ISO 15875 class 4/8 bar [DIN approval mark] 3V279 PE-X
Max. continuous operating pressure (water at 20 °C)	19.1 bar (safety factor SF = 1.25 (according to DIN EN ISO 15875 for 20 °C), for 50 operating years
Max. continuous operating pressure (water at 70 °C)	8.8 bar (safety factor SF = 1.5 (according to DIN EN ISO 16893), for 50 operating years
Application class according to DIN EN ISO 15875	4 (underfloor heating)
At permissible operating pressure	8 bar
DIN CERTCO reg. no.	3V 279 PE-Xa
Pipe couplings Uponor	9.9 x 1.1 type couplings
Optimum installation temperature	≥ 0 °C
UV protection	lightproof cardboard box (unused piping must be stored in cardboard box!)

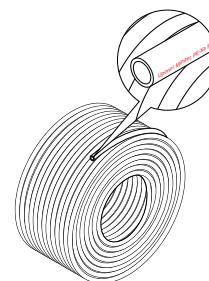

Installation Instructions - Solid Screed Floor

Pipe Dimensions	9.9mm PEX	12mm PEX	16mm PEX	✓	16mm MLC	✓	20mm PEX	✓
-----------------	-----------	----------	----------	---	----------	---	----------	---

When installing underfloor heating (UFH) within a solid screed, there are a number of different methods of fixing the UFH pipe into position, onto and above the floor grade insulation. The two most common methods are:-

1. Kombi Klip

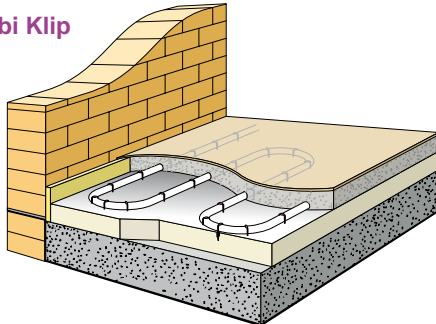

If using pipe-positioning plates, please use the installation instructions enclosed in each box to assist with the laying of the plates.

Surface Preparation

The floor must be level and swept clean of dust and debris before laying the insulation.

Pipe Bends

When laying the pipe, do not force the pipe into bends. It is easier to lay the pipe with a large radius and then gently pull the pipe to the required bend.

Installation



- Fix the edge insulation continuously around all internal and external wall edges, using the adhesive backing. When installed correctly the PE-skirt will be facing out from the wall and the embossed 'Uponor' will be legible.

Once the screed has dried and cured, the edge strip can be trimmed down.

- Lay the floor insulation over the entire floor area butting up to the edge strip, ensuring the PE skirt is overlapped and taped onto the floor insulation. If using Uponor insulation or another foil faced insulation board, tape the joints of all adjoining sections of insulation together to prevent screed slipping down between sheets of insulation and creating a cold bridge. Alternatively, lay a protective layer over the insulation.
- Fix the manifold into position, ensuring there is sufficient room to connect the water temperature controls and flow and return pipework.

2. Clip Rail and U-clip

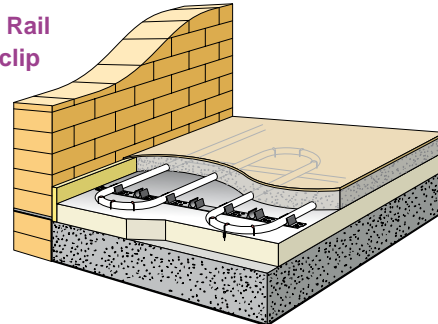

It is normal for the pipe to bulge out slightly like a 'light bulb' on 180° turns, especially where pipe centres are closer than the standard pipe spacing.

Do not pull the pipe too tight or it may kink.

Pipe Centres

When installing onto floor grade insulation, pipes should be spaced away, 100mm (16mm pipes) and 150mm (for 20mm pipe), from the wall edges. Thereafter, in modern well-insulated buildings the UFH pipe is generally installed at standard centres, 200mm (16mm pipes) and 300mm (for 20mm pipe) across the active floor area, unless otherwise specified.

- If using Clip Rail & U-clips, lay the rail across the floor to create a matrix for the UFH pipe. Use the self-adhesive backing to hold the rail onto the insulation. For meander pattern pipe installation, set the rail out on the insulation at a maximum 500mm spacing from two opposite wall edges and a maximum 2000mm spacing between clip rails. Ensure the clip rail is at a 90° angle to the coldest external wall.

Alternatively, if you wish to lay the pipe in a bifilar pattern, lay the clip rail over the insulation in a cross/star pattern with each clip rail strip converging in the centre of the floor area to be heated.

Once you are happy with the clip rail layout in relation to your proposed pipe configuration and routes, fix the rail permanently to the insulation by pushing the 'U'-clips through the holes provided in the clip rail at the leading and trailing end of the rail. If the length of rail exceeds 1m use additional U-clips at 500mm intervals.

On the actual pipe bends you may wish to use the U-clips directly over the pipe and into the insulation for extra hold. Insert u-clips at a 45° angle to gain maximum hold.

If the floor grade insulation is already installed below the floor slab and the additional insulation laid over the concrete slab is not sufficient to fix Uponor U-clips, we would advise fixing the rail directly to the sub concrete floor using suitable floor fixings (screws and plugs).

If using the Kombi Klips to fasten the pipe to the floor grade insulation, clip the pipe at 500mm intervals. More clips may be necessary on the pipe bends. Minimum 35mm insulation depth is required for the Kombi long and 25mm for the short. To assist with fixing the Kombi clips into the insulation we would advise using the Kombi Tacker Gun (Item no. 1002295)

Clip Rail Fixing

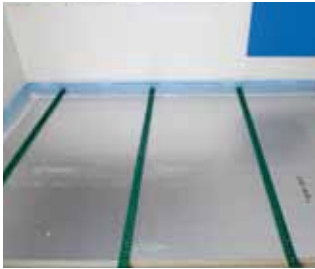

Kombi Klip Fixing



Laying the UFH Pipe

In order to prevent the floor from overheating directly below the manifold or through doorways, where pipes are congested together, we would advise insulating the pipe, especially if they are not used to heat the room through which they pass.

- Identify each floor area to be covered by each coil/loop of UFH pipe. If you have had a design prepared by Uponor, the rooms to be heated and the coil lengths allocated to each area will be identified on your quotation and/or design layout drawing.
- When installing the pipe it is important to ensure the pipes do not cross over each other, therefore time should be spent, before actually laying any pipe, configuring the route for the feed pipes from the manifold location to their respective area/room to be heated.
- Typically, feed pipes pass through door openings, etc. However, where possible, particularly to areas adjoining the manifold location, feed pipes could be taken directly through partition walls and into their respective rooms. This will also help alleviate any congestion around the manifold location. Ensure all holes drilled are below the screed floor finished level. Also, when threading the pipe through the hole ensure it has been capped off and there are no

sharp edges, which could score and damage the pipe. It is recommended that the UFH pipes, when passing through walls, are sleeved with Uponor protective conduit.

- Once you have a clear picture of the installation, you can begin to install and lay the pipe. Firstly thread the first coil end behind the return manifold and connect onto the manifold flow port. If passing through a partition wall first thread the pipe through the hole and up behind the return manifold.

If using PEX pipe, 'pipe bend supports' must be fitted on every loop at the point where the pipes rise from the floor/insulation and up to connect to the manifold, i.e. 2 required per loop.

In all cases, the pipe should be laid so that the flow direction is to the coldest area of the room first, for example, under windows and along external walls.

To assist with installation, Uponor pipe is marked at every metre length. It is good practice to make a note of the starting metre at the manifold and keep referencing how much pipe has been laid whilst installing over the intended floor area. This will help ensure you leave sufficient pipe to return to the manifold. Each loop should be installed without any joints in the floor.

Installing the Meander Pattern

Once you have entered the room/area to be covered, first lay the flow pipe around the perimeter with a gap, 100mm (for 16mm pipes) and 150mm (for 20mm pipe), from the wall to the coldest area and then meander up and down across the floor area back towards the point of entry, following the same route back to the manifold, clipping the pipe as necessary depending on the chosen method of fixing. On returning back to the manifold connect the tail end of the pipe to the corresponding return port on the manifold.

Meander pattern

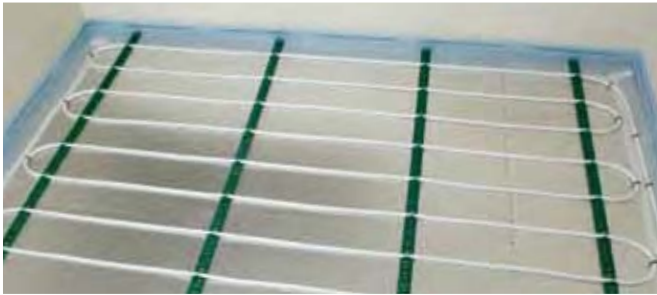

Installing the Bifilar Pattern

Once you have entered the room/area to be covered, lay the pipe around the perimeter of the active floor area to be covered, maintaining a gap, 100mm (for 16mm pipes) and 150mm (for 20mm pipe), from the wall edge and clipping the pipe as necessary. When you have circled the area and are back at your starting point, follow the same route around, but this time, at two times the design pipe spacing.

For example, if installing at 200mm centres across the floor area, follow the same route at 400mm centres. Continue spiralling this way until reaching the centre of the area. At this point turn back on yourself, making a hairpin turn and begin laying the pipe outwards centrally between the pipes already fixed on your inward journey, thus ensuring even 200mm pipe centres across the whole floor area and more importantly an even floor temperature. On returning back to the manifold connect the tail end pipe to the corresponding return port on the manifold.

Bifilar pattern



Screed Expansion Joints

Where pipes are to cross over a screed expansion joint, use a small section of conduit over the pipe, up to a minimum of 200mm either side of the joint.



Inspection

Once the pipes have been laid, inspect the system to ensure all is as it should be.

Where used, snip back all sharp edges of mesh that may contact the pipe. Clip down any sections that have lifted to stop the pipe being too close to the finished surface.

Pressure Testing

Once all the pipes have been laid and connected to the manifold, fill and pressure test the system.

Sand-Cement Screed

Lay the screed as soon as possible to protect the pipes. At all times avoid unnecessary foot traffic.

Self Attaching System

Optimal Productivity and Performance

PROJECT SAVINGS

- **Remove work steps**
28db impact noise reduction can remove the need for installing a resilient acoustic layer
Built in membrane removes the need for installing a polythene layer above the roll insulation
- **Reduce overall build programme**
- **Save on cost of supplying and installing a resilient acoustic layer**
- **Halve the time of installing an UFH system or halve the installation cost**

ACOUSTIC & INSULATION QUALITIES

- **28db impact noise reduction**
Tested to DIN4109
Identical laboratory methods to BSEN ISO 140-8:1998
- **Better than some of the leading acoustic underlay products**
- **Potential for significant savings on supply and installation costs**
- **Meets BSEN 1264 insulation requirements for floors with heated rooms below**

PEX-a 16x1.8mm UFH PIPE

- **25 year manufacturing defect warranty**
- **Design life in excess of 50 years in accordance with DIN 16892**
- **Design pressure of 6 bar at 70°C**
- **Available in coil sizes up to 640m**
- **Oxygen diffusion barrier conforming to DIN 4726**
- **Manufactured to ISO 9001 & 14001**
- **3.3 billion metres of pipe sold since 1972**
- **Conforms to EN ISO 15875**



Installation Instructions - Self Attaching System (Solid Screed)

Pipe Dimensions	9.9mm PEX	12mm PEX	16mm PEX	✓	16mm MLC	20mm PEX
-----------------	-----------	----------	----------	---	----------	----------

The edging strip must be fitted before the Uponor self-attaching system insulation is laid.

Laying the Uponor self-attaching- system insulation
The Uponor self-attaching-system insulation is to be preferably laid in continuous strips in the room's longitudinal direction. For easier distribution of the heating loops, the marking grid should match the parallel insulating strips. Remaining surfaces in recesses, door opening and strips remaining along the walls are to be subsequently filled in with the remaining insulation. Always place the "free-hand" cut sides of the boards against the edging strip to eliminate gaps in the insulation.

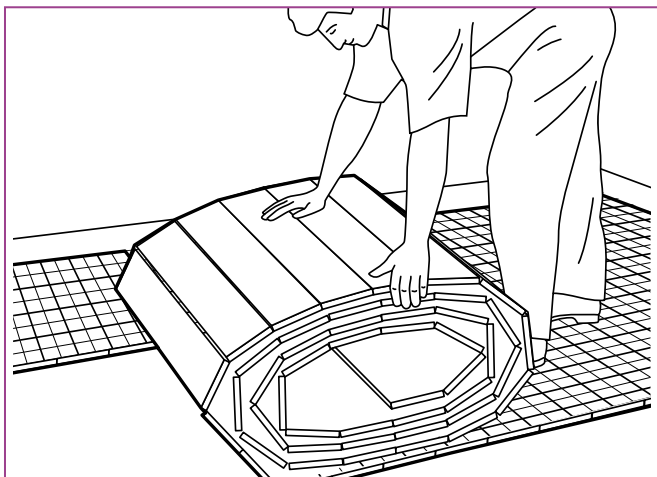

Pipe laying

The heating pipes are laid on the boards at the predetermined distance without using tools. The microscopic hooks meshing with the looped sheets are sufficient to ensure that the pipes are fixed to the boards. No additional fixing is required. The minimum allowed bending radii of the pipes are to be maintained. All known methods of pipe laying are possible. It makes sense to mark the supply and return of the heating loops to ensure correct distributor connection. Uponor recommends installing pipes in the bifilar (snail) pattern.

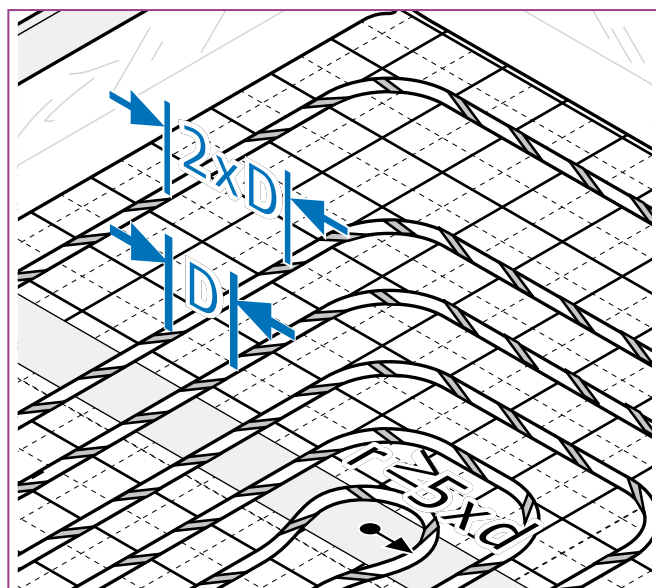

Additional insulation

Additional heat insulation may be needed to comply with DIN EN 1264-4 and EnEV requirements.

Masking the self-attaching system insulation joints

Masking all insulating strips (together with the bonded edging strip apron) creates a sealed trough ready to accept the heating screed. Precise masking stops any screed or screed water from penetrating the insulation as well as stopping acoustical bridges from being formed.

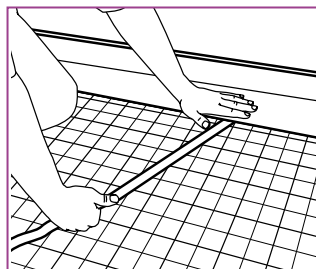
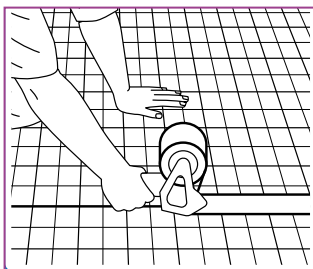

Sealing the edging strip

To eliminate all gaps or cavities the edging strip foil apron must be bonded to the insulation boards. This keeps the foil from ripping and prevents the penetration of screed or screed water.

Other notes

The radiant heating pipe is to be protected with Uponor protective sleeves in the area of the expansion joints. Before pouring the screed a pressure test is to be made in accordance with BS EN 1264-4. A test report is to be prepared.

The exposed parts of the edging strip may only be removed after completion of the flooring or when laying textiles and flexible coverings only after the hardening of the filler at the predetermined breaking points.

Before any floor covering is laid the screed must be heated up in accordance with BS EN 1264 part 4. For proprietary screeds please consult with the manufacturer for curing times and heat climatisation procedures.

Roll Insulation

The following pages are intended as a quick reference guide where you can see the main steps of installing self attaching system.

For more details please refer to the installation manuals that can be found inside the packaging of the products.

Floor installation main steps

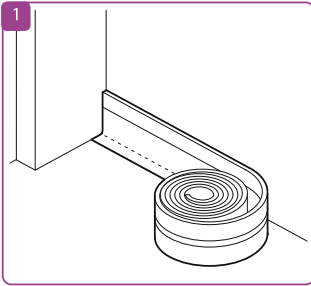

1 The edging strip should be installed prior to the insulation

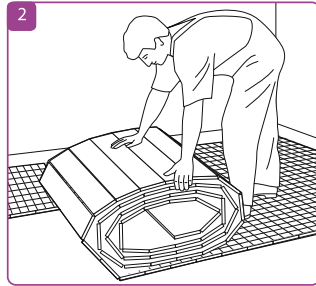

2 Lay the insulation roll length ways in the room and by matching the pre-printed grid

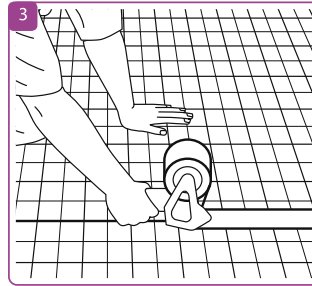

3 Seal the panels side by side using tape

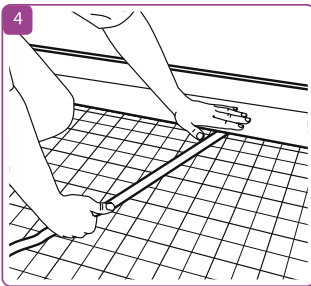

4 Seal the edging strip along the perimeter of the insulation

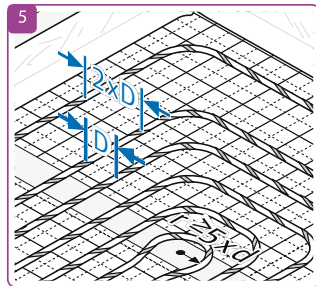

5 Lay the pipe by applying pressure with your foot to attach it to the insulation panel. Uponor recommends installing the pipe in a bifilar (snail) pattern. Bifilar pattern details shown on page 24.

Pipe Leading Tool

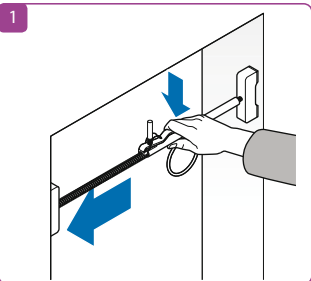

1 Position the pipe leading tool within the door frame, close to the top

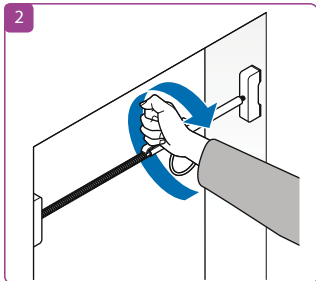

2 When you are happy with the position, and the ring is on the underside lock the tool in place

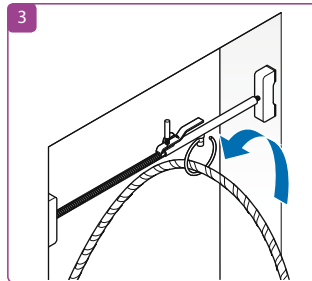

3 Insert the self attaching system pipe through the ring

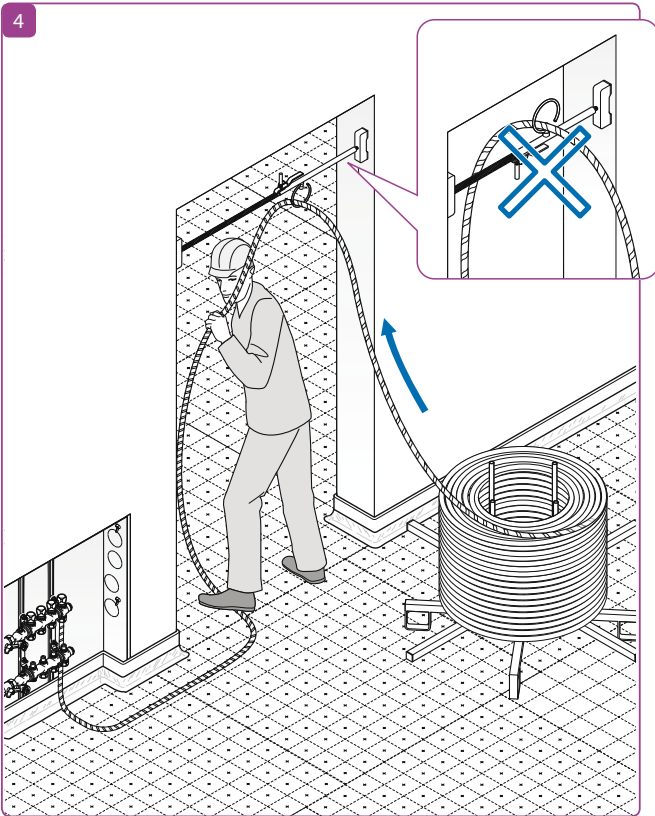

Start laying the self attaching system pipe having previously positioned the de-coiler in an adjacent room

*When connecting pipe to manifold use a 90° bend support for creating a stable bend.

Pipe Leading Tool

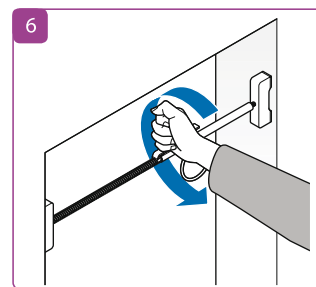
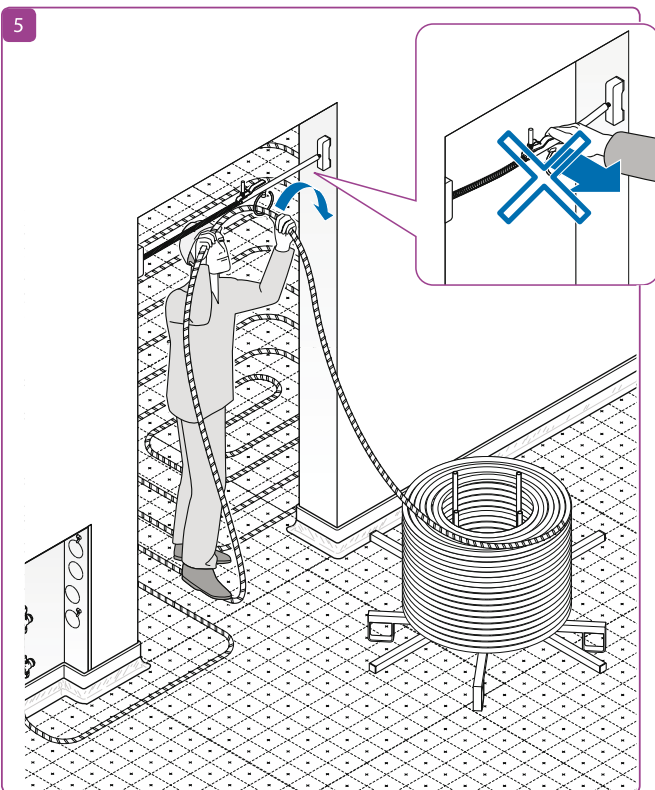

Remove the self attaching system pipe from the pipe leading tool but do not try to remove the tool itself

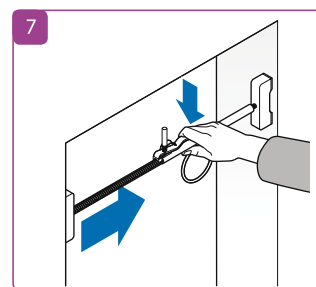

Unlock the pipe leading tool

Compression Adapter

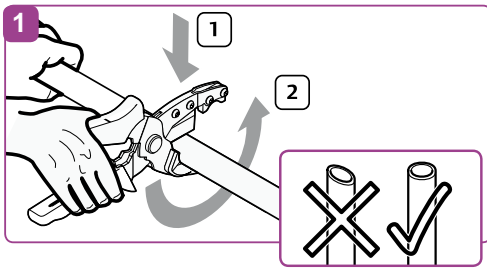

1. Cutting to length

Cut the pipe to length at right angles with a pipe cutter. The edges must be straight and burr-free.

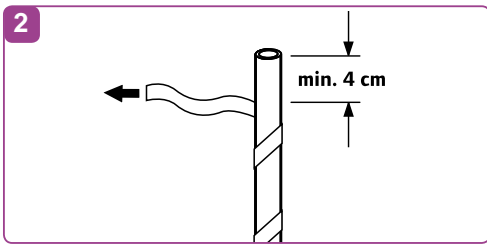

2. Removing the self-attaching-system strip

Loosen and cut off at least 4 cm of the self-attaching system strip from the end of the pipe.

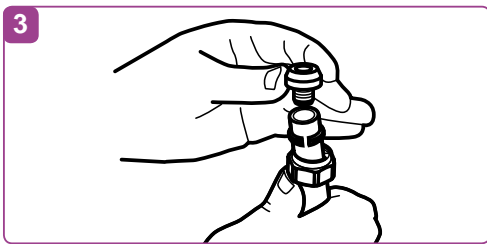

3. Installation of the union nut and locking ring

First push the union nut and then the locking ring onto the end of pipe.

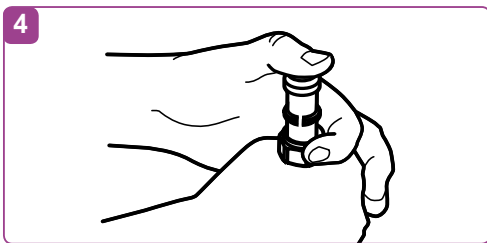

4. Installation of the pipe inset (support sleeves)

Push the pipe inset (support sleeves) by hand into the pipe until the positive stop is reached. If manual force is not sufficient, it is possible to use a plastic hammer.

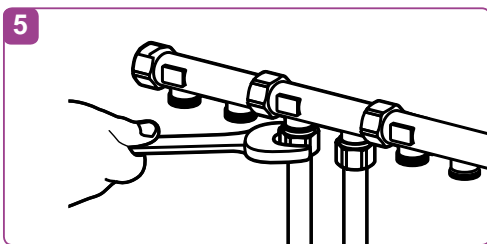

5. Connection to the distributor

Attach the pipe to the distributor and secure the nut by hand. Then tighten the nut with a wrench until the torque noticeably increases.

Please note

With threaded locking ring connectors you must always use pipe inserts (support sleeves). If the compression adapter is loosened a new locking ring must be used. The reuse of a locking ring is not allowed.

Installation Instructions - Timber Suspended Floor (Heat Emission Plates)

Pipe Dimensions	9.9mm PEX	12mm PEX	16mm PEX	✓	16mm MLC	✓	20mm PEX	✓
-----------------	-----------	----------	----------	---	----------	---	----------	---

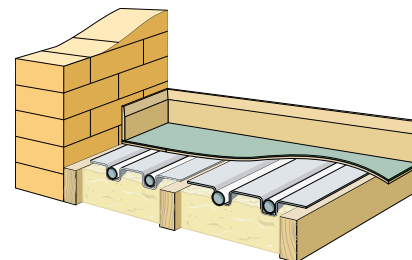

Siccus Heat Emission Plates

Uponor have developed various heat emission plates (HEP's) to suit many timber floor applications. There are 4 plate sizes suitable for Uponor pipes, as follows:

HEP300

For use with timber suspended or battened floors with joists/supports at 300mm centres. 20mm PEX pipe only.

HEP400

For use with timber suspended or battened floors with joists/supports at 400mm centres.

HEP411

For use with sprung timber floors with battens spaced at 411mm centres, such as Junckers Unobat and Blubat Sports Floor Systems, suspended or battened floors with joists/supports at 411mm centres. 20mm PEX pipe only.

Insulation

It is essential that insulation is installed between the joists, as close to the underside of the plates as possible.

Typically, a minimum 100mm of mineral wool insulation is used, however, where relevant, the insulation used must comply with current Part L and Part E (England & Wales) of the Building Regulations.

The relevant Building Standard codes for other countries are as follows:

Northern Ireland - Technical Booklets F (Conservation of Fuel and Energy) and G (Sound).

Republic of Ireland - Parts L (Conservation of Fuel and Energy) and E (Sound)

Scotland - Sections 6 (Energy) & 5 (Sound).

Item	Product code	Dimensions (m)	No. of pipe tracks	Plates/pack	*Pack Coverage (m ²)
HEP400 (16mm)	1034365	0.38 x 1.15	Two	28	15.3
HEP300 (20mm)	1009132	0.28 x 1.15	Single	40	16.0
HEP400 (20mm)	1034492	0.38 x 1.15	Two	20	11.0
HEP411 (20mm)	1034491	0.405 x 1.15	Two	20	11.8

*Equates to approximately 80% floor coverage

Installation of Siccus Heat Emission Plates



- The plates are for heat distribution only and are not structural. They are easily damaged and it is very important that no other trades are allowed where the UFH is being installed. The heat emission plates normally cover approximately 80% of the floor area. Plates should never touch each other, as they expand when heated and can create noise. Plates are only laid under straight runs of pipe.
- Ensure all insulation and the necessary battening work is installed and complete, prior to laying of the plates. If cross battening, this is best achieved using 25mm x 100mm battens. Leave the ends of the battens loose so that the pipe loop can be laid beyond the end of or under the cross batten. Fix batten ends before laying floor.
- Lay the heat emission plates across the joists without fixing, leaving a gap between the ends and sides of each plate. Check to ensure appropriate number of plates are evenly spread out across the entire area before fixing.

Lay the first plates at each end of the room, leaving a minimum 300mm space (16mm) and 450mm space (20mm) space from the wall edge, to enable the pipe to bend 180 degrees around.

Thereafter space the plates out evenly ensuring gaps between plates are at least 10mm but less than 100mm. Use any sections of plates in the middle of the room.

- When the plates have been laid on the first row of joists, fix these into position and repeat the process for the remaining joists.
- Careful consideration should be given to the location of plates around the manifold area and along feed pipe routes, where the UFH pipes congregate together, cross joists at right angles and are non standard pipe centres.

Cutting Plates

The plates are scored $\frac{1}{3}$ from one end of the plate and at $\frac{1}{3}$ from the other and are easily split along these score lines. Keep the pipe groove uppermost and sharply break the plate over a straight edge. If different lengths are required, score the plate deeply with a Stanley knife and cut along the pipe groove with a hacksaw.

Clean off the burrs in the pipe groove to prevent damage to the pipe.

Installation Instructions - Siccus Floating Floor System

Pipe Dimensions	9.9mm PEX	12mm PEX	✓	16mm PEX	✓	16mm MLC	✓	20mm PEX	✓
-----------------	-----------	----------	---	----------	---	----------	---	----------	---

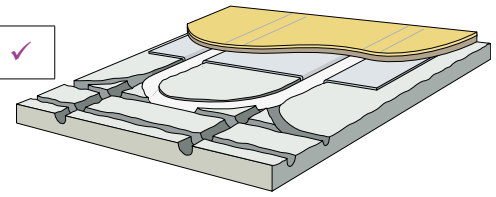

Siccus Floating Floor System

The Floating Floor Panel can be laid on almost any existing floor surface. It is an ideal system for retrofitting UFH, or as an alternative to screeded floors.

Siccus Floating Floor Panels

The pre-grooved insulation floor panel is made of polystyrene and designed for use with heat emission plates to distribute the heat over a wide area. When used on a ground floor installation, additional insulation may be required to ensure compliance with Building Regulations and to minimize downward losses ($\leq 10W/m^2$).

NEW Siccus FX

The new Siccus FX system is an alternative to traditional floating floors with a bonded foil heat emitting top surface as opposed to separate heat emission plates. The Siccus FX system can also be used for timber suspended and raised access floors.

Surface Preparation

All subfloors should be clean, rigid and level prior to installing the underfloor heating system. Any projections must be levelled off as any imperfections in the slab will be projected through to the finished floor. The recommended maximum surface irregularity under a 3m long straight edge is 3mm in all directions. If a liquid based DPM has been used or self-levelling compound, it must be allowed to dry completely before laying any insulation. Where moisture control barriers are required these should be installed prior to laying the floating floor panels. It is a prudent precaution to install a moisture control barrier on all existing solid floors where the condition of the existing moisture barrier buried within the existing floor construction is unknown.

Dimensional Details for 12mm PEX pipe

12mm PEX pipe	Panel thickness (mm)	Length x width (m)	pipe spacing (mm)
Main panel c/w heat emission plate	15	1.2 x 0.75	125
Feed & return panel	15	1.2 x 0.75	62.5
Heat emission plate	0.3	1.18 x 0.11	-

Dimensional Details for 16mm PEX and 16mm MLC pipes

16mm PEX & 16mm MLC	Panel thickness (mm)	Length x width (m)	pipe spacing (mm)
Panels for 16mm pipes	50	1.2 x 1.2	200
Double heat emission plate	-	1.15 x 0.38	
Insulation panel with bonded foil	30	1.2 x 0.8	

NEW Siccus FX

16mm PEX	Panel thickness (mm)	Length x width (m)	pipe spacing (mm)
Insulation panel with bonded foil	30	1.2 x 0.8	200

Dimensional Details for 20mm PEX pipe

20mm PEX pipe	Panel thickness (mm)	Length x width (m)	pipe spacing (mm)
Panels for 20mm pipes	30	1.2 x 0.79	300
	50	1.2 x 0.79	
Single heat emission plate	-	1.15 x 0.28	

Laying the Panels

Take care with the panels as they may easily be damaged. Lay the pre-grooved insulation panels across the whole floor, symmetrically keeping the grooves running across the floor area. It is preferable to stagger the rows of panels in a brick pattern to avoid 4 corners of adjacent sheets lining up. Avoid using small pieces of panels, especially around the perimeter.

Additional Notes for 12mm PEX Floating Floors:

Visualise the route the feed pipes will take from the manifold to the heated room/area. If the manifold has 3 or more loops, you need to incorporate Feed Panels into the installation, this will allow feeds to be run at c/c 62.5mm pipe centres. If used determine the location of the Feed Panels, prior to laying the main Floor Panels within each room/area. The main Floor Panels have both bends and feed grooves at the panel header. These can be revealed by breaking off a small section of each heat emission plate.

To maintain an even floor height, 15mm plywood or chipboard (supplied by others) should be installed where underfloor heating is omitted, i.e. under baths, showers, kitchen units, etc. Insulation panel off-cuts should be used as infill pieces at doorways, etc.

Cutting the Panels or Extra Grooves

It will be necessary to cut the panels in places, particularly in doorways and near to the manifold where the feed pipes congregate at less than standard centres. Use either a sharp long bladed knife or hand saw to cut the insulation boards. Additional grooves can be made in the insulation using a 230 volt polystyrene hot wire cutter (product code: 1006290). To cut 20mm PEX a replacement head (product code: 1002072) will also be required. Alternatively use a sharp knife or router to cut the groove.

Siccus Floating floor system for 16mm pipes



Siccus Floating Floor System 12

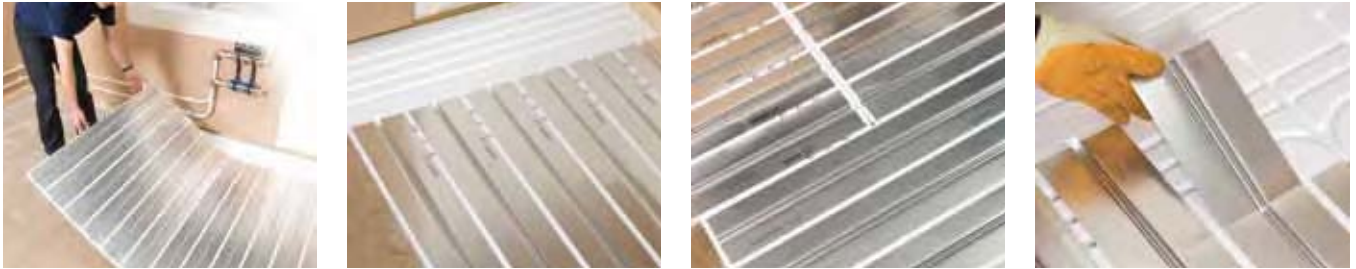

Laying the Siccus Heat Emission Plates

Note: Not applicable for Siccus FX system

For 16 and 20mm pipes the number of plates allowed is given in the materials schedule. Plates normally cover approximately 80% of the floor area. Lay the heat emission plates in the required configuration, prior to pressing them into the grooves in the insulation panels. This ensures that the appropriate quantity of plates, is set out across the entire area. Where possible, configure the plate positions to run parallel with the coldest external wall and windows. Leave a gap between the ends of the plates; there will normally be a gap between the sides of the plates. Where extra grooves are cut into the insulation, the edges of the plates should be cut to avoid them overlapping.

- Start at each end of the room with full size plates, leaving a 300mm gap from the wall edge for bending the UFH pipe through 180 degrees.
- Fill in the middle with sections of plates.

- Space the plates out evenly ensuring gaps are at least 10mm but less than 100mm.
- When the room is evenly covered with plates press them into the grooves in the polystyrene.
- For 12mm PEX (System 12) Snap off' heat emission plates removed from the floor panels should be used on the pipe tails installed in the outer grooves of floor and feeder panels.

Cutting Plates

Apart from System 12 plates, plates are scored $\frac{1}{3}$ from one end of the plate and at $\frac{1}{6}$ from the other and are easily split along these score lines. Keep the pipe groove uppermost and sharply break the plate over a straight edge. If different lengths are required, score the plate deeply with a Stanley knife and cut along the pipe groove with a hacksaw. Clean off the burrs in the pipe groove to prevent damage to the pipe.



Pipe Bends

When laying the pipe, do not force the pipe into bends. It is easier to lay the pipe with a large radius and gently pull the pipe to the required bend before pressing into the next plate and insulation board.

Do not pull the pipe too tight or it may kink.

Pipe Centres

The plates and insulation boards are manufactured with grooves set at the following pipe centres;

12mm PEX	-	125mm
16mm PEX	-	200mm
16mm MLC	-	200mm
20mm PEX	-	300mm

Laying the Pipe

- Where possible, the design will ensure that the flow pipes are directed to the coldest part of the room.
- Identify each floor area to be covered by each coil/loop of pipe (if you have received a design prepared by Uponor, the rooms to be heated and coils allocated can be identified on the quotation and/or layout drawings).
- When installing the pipe it is important to ensure the pipes do not cross over each other, therefore time should be spent, before actually laying any pipe, configuring the route for the feed pipes from the manifold location to their respective area/room to be heated.
- Typically feed pipes from the manifold go through door openings. However, where possible, to avoid any congestion around the manifold and through rooms adjoining the manifold location, feed pipes can be taken directly through partition walls and into the respective room. Ensure any holes drilled are below the floor level. When threading the pipe through the hole ensure it has been capped off and there are no sharp edges, which could score and damage the pipe. It is recommended that the UFH pipes, when passing through walls, are sleeved with Uponor protective conduit.
- Once you have a clear picture of the installation, you can begin to install and lay the pipe. First thread the first coil end behind the return manifold and connect onto the flow port manifold. If passing through a partition wall, first thread the pipe through the hole and up behind the return manifold.
If using PEX pipe, 'pipe bend supports' must be fitted on every loop at the point where the pipe rises from the floor to connect to the manifold, i.e. 2 required per loop.
- Lay the pipe, pressing it into the plates grooves by hand or gently by foot. Where possible take the flow pipe to the coldest section of the room and meander the pipe up and down across the floor area towards the start position.

- It may be necessary to weigh down loop bends (do not use sharp objects), prior to laying the flooring and until the pipe has relaxed.
- Once the loop has been laid, take the pipe back to the manifold, following the same route out and connect the tail pipe to the corresponding return port on the manifold.

Inspection

Once the pipes have been laid, it is important to inspect the system before laying the floor, to ensure the installation is correct and pipes are held firmly away from any possible damage.

Pressure Testing

Once all the pipes have been laid and connected to the manifold, fill & pressure test the system as per instructions in Filling, Venting and Pressure Testing section on page 81.

Decking

The area should be decked immediately to protect the system. Foot traffic must be prohibited until this is carried out to protect the pipe and the panels.

Laminate floor finishes should be a minimum of 7mm thick with inter-locking joints.

Chipboard or plywood floor deck should be a minimum of 15mm thick with glued tongue and grooved edges.

If required an intermediate layer between the underfloor heating and the finish floor can be installed to minimise the risk of movement/expansion noise; use lightweight flooring cardboard, heavy gauge paper, polythene sheet or finish floor supplier's/manufacture's solution to compensate for uneven and flexible subfloors.

As an alternative to laying tongue & groove chipboard flooring over the underfloor heating, 'Fermacell' or 'Knauf' dry flooring element (20mm or 25mm depth) can be used as it offers a lower resistance to heat transfer than chipboard and plywood.

The final floor deck should be installed as per the manufacturers/suppliers instructions.

New Siccus FX Outputs

Pipe specification:
16mm O/D PEX

Floor construction:
Timber Suspended or
Floating Floor with foil
faced insulation

Floor decking:
18 mm chipboard
Water temp drop [K]: 5

Mean water temp MWT °C	Design room temp Rt °C
45	16
	18
	20
	22
	24
50	16
	18
	20
	22
	24
55	16
	18
	20
	22
	24

Pipe pitch, Vz [mm]			
150			
Floor covering resistance, R _{λ,β} [m ² K/W]			
0.01	0.05	0.1	0.15
Heat emission, q [w/m ²]			
69.4	63.6	55	49.2
64.6	59.2	51.2	45.8
59.8	54.8	47.3	42.4
55	50.4	43.5	38.9
50.2	46	39.7	35.5
81.5	74.7	64.5	57.7
76.6	70.3	60.7	54.3
71.8	65.8	56.9	50.9
67	61.4	53.1	47.5
62.2	57	49.2	44.1
93.5	85.7	74	66.2
88.7	81.3	70.2	62.8
83.9	76.9	66.4	59.4
79	72.5	62.6	56
74.2	68.1	58.8	52.6
Exceeds 70 W/m ² limit			

Installation Instructions - Tignum Timber Panel System

Pipe Dimensions	9.9mm PEX	12mm PEX	✓	16mm PEX	16mm MLC	20mm PEX
-----------------	-----------	----------	---	----------	----------	----------

Tignum Panel Benefits

- Low build height
- Fast response time
- Dry trade system
- No joints below the floor
- Reduced product inventory
- Ideal for renovation and new build projects

Tignum Panel Dimensions

- Main Panel 1200 x 600 x 15mm
- Turn Panel (Multi directional) 600 x 300 x 15mm
- Heat emission plates (with snap points) 1180 x 110mm
- Pipe spacing c/c 150mm

A low profile underfloor heating system incorporating 15mm chipboard panels with grooves to accept thin aluminium heat emission plates and 12mm PEX pipes. System comprises of only 2 panels, main and turning, for a minimal number of installation components.

With the relatively wide spacing of 150mm between pipe runs, means that only 7 linear metres of 12mm pipe is required per m² of floor area.

The system has been engineered for speed and ease of installation and can be fixed on top of an even base.

And best of all, the system has an ultra low profile of only 15mm making it ideal for integration into new builds and for retrofit floors.

Tignum 12 Low Build Height system

Insulation
Where possible insulation should be installed below the underfloor heating system. If omitted due to practical reasons the commissioning settings may need increasing to maintain output performance.

Finish Flooring
Finish floor should be installed as soon as possible to protect the system. If necessary temporary protection boards should be used whilst other trades access the underfloor system area prior to finish floor installation.

Floor Level
Sub floors should be clean and level prior to installation. All sub-floors should be structurally sound and suitable for the loads imposed.

Refer to Uponor installation instructions for further information.

Finished Floor Options

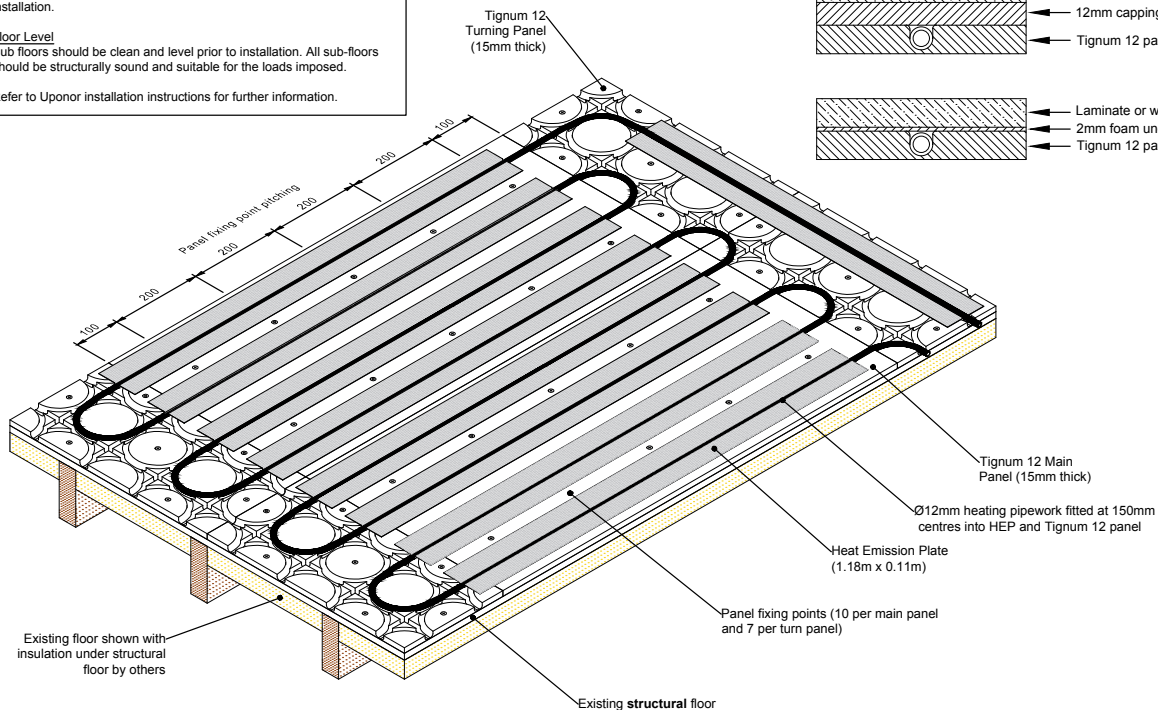
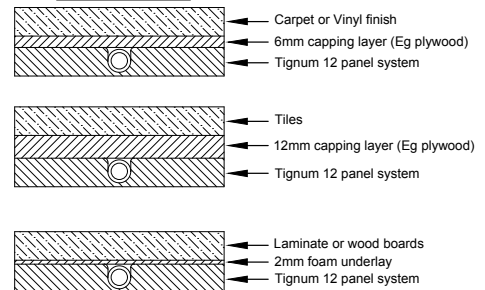

Layout Planning and Area Adjacent to Manifold

The layout of the Tignum 12 panels must be carefully planned before installation begins. The result of a well-planned layout will be minimal material wastage and a tidy installation.

First, determine where the manifold is to be located and then visualise the route the pipe feeds will take. The floor area close to the manifold will have tightly spaced pipes and, depending on the quantity of pipe loops, may be installed directly on top of the sub-floor decking. Later the spaces around the pipe can be filled in with off-cuts of battens or semi-dry sand and cement mix.

Panel Direction

Decide the direction that Tignum panels will run.

Tile floor finish:

Run the panels parallel to the outside wall with the greatest heat loss if possible. For joisted floors, running the tracked panels perpendicular to the floor joists will strengthen the floor, reduce deflection and give a more stable base for fixing the tiles. A capping layer over the timber panels is required for tile floor coverings. The capping layer should be suitable for floor finish and could be a 12mm plywood, gypsum/cement based board, or similar.

Carpet or vinyl floor finish:

Run the panels parallel to the outside wall with the greatest heat loss if possible. For joisted floors, running the tracked panels perpendicular to the floor joists will strengthen the floor and reduce deflection. A capping layer over the timber panels is required for vinyl and linoleum floor coverings. The capping layer should be suitable for floor finish and could be a 6mm plywood, gypsum/cement based board, or similar. Carpet underlays must have a maximum TOG value of 1 and be suitable for underfloor heating. Do not exceed a combined TOG value of 2.5 for the underlay and carpet.

Hardwood or laminate flooring:

Always run the panels perpendicular to the hardwood/ laminate flooring (regardless of joist direction). This will keep pipe visible during the fixing of the floor finish and reduce the risk of puncturing a pipe. Floating hardwood or laminate floor coverings should have tongue and groove inter-locking joints. If using an underlay, use 2mm thick polyethylene foam or similar material offering a low thermal resistance.

Preliminary Layout

Room by room, determine direction of main Tignum 12 main panels and then position and number of Tignum 12 turn panel rows. Turn panels will be required at the head and foot of main panel runs. The number of loops in the room will determine the amount of turn panel rows - see table below.

Table of turn plate rows

Loops in room	Number of turn plate rows
1	2
2	2.5
3	3.5
4	4.5
5	5.5
6	6.5

A gap of 10mm should be allowed between Tignum 12 panels and walls for expansion purposes.

Then consideration needs to be given to pipes crossing door thresholds. Tignum 12 panels can be used for up to 4 pipe tails (2 loops) entering a room through a standard door width. For more than 2 loops install battens to allow for tighter pipe spacings.

Plan the route for pipe tails between room(s) and the manifold and determine the location of Tignum 12 boards and/or support battens.

Area around the manifold can get congested with pipes so leave this area free until after pipes have been laid.

Panel Installation

- Use a circular saw or similar for cutting Tignum 12 panels and any additional support battens.
- Always follow the floor finish manufactures recommendation regarding installation. Where moisture control barriers are required these should be installed prior to laying the timber panels. It is a prudent precaution to install a moisture control barrier on all existing solid floors where the condition of the existing moisture barrier buried within the floor construction is unknown.
- Leave an expansion gap of 10mm between Tignum 12 panels and walls. If installing pipe tail battens leave a gap of 7mm from walls.
- Only fix panels, using pre-drilled screw holes, after heat emission plates and pipes have been installed.

Multiple Loop Configurations Using Pipe Tail Battens

The main board and turn plates are ideal for installation of any number of loops in a single room and does not require any additional tail run considerations. With two or more loops passing through a single room additional pipe tail battens are recommended to avoid using excessive floor space using turn plates for tails and maintaining zone control. Battens can be made from 15mm thick chipboard, OSB or other particle board, and should be cut to the required width using a circular saw or equivalent tool. Alternatively, available softwood battens of the correct dimensions can be used.

Wall batten: 15mm thick x 36mm wide
Outer batten: 15mm thick x 68mm wide

The outer edge of wall battens should be installed 75mm from the wall to provide an expansion and movement gap around the perimeter. Subsequent outer battens should be installed at 50mm pitch from the outer edge of the wall batten. This arrangement leaves sufficient gap for later installation of both pipe and heat emission plates.

Internal and External Bends Using Pipe Tail Battens Room Entry Layout

Two options considered depending on the actual project layout and the number of loops feeding a room.

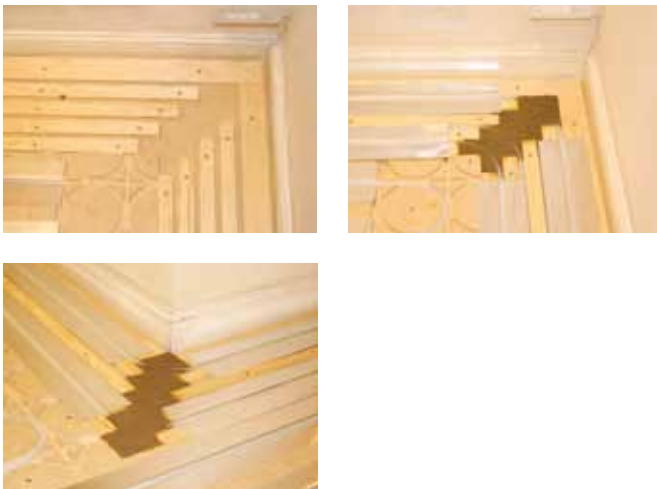

Option 1 – Door entry using standard Tignum panels

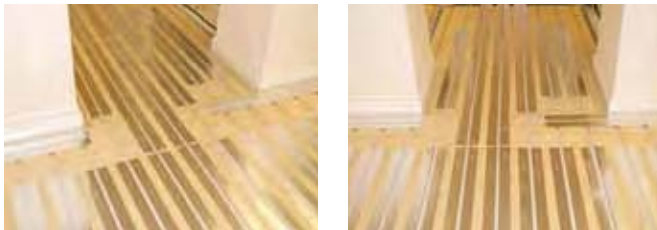

Option 2 – Door entry using pipe tail battens



Single Room Panel and Turn Plate Installation

After installation of any additional feed battens within rooms, the main panels and turn plates can be set out in the individual rooms. It is strongly recommended the boards are loose laid and fixed after the heat emission plates and pipe are installed; this will ensure board grooves are aligned prior to fixing them to the subfloor.

A single loop room requires two turn plate rows at either end of the room.

For a two loop room an additional half row of turn plates is required at one end of the room.

Rooms with more than two loops will require one additional row of turn plates for each loop over the two loop requirement given above.

See Table of Turn Plate Rows in Preliminary Layout Section.

Two Loop Room Installation Example Install Tignum 12 Panels



Final Floor Preparation

- To maintain an even floor height, 15mm plywood or chipboard (supplied by others) should be installed where underfloor heating is omitted, i.e. under baths, showers, kitchen units, etc. Timber panel off-cuts should be used as infill pieces at doorways, etc.
- When installing panels on a suspended wood floor, with pipe feeds in the joist space below the tracked panels, determine the location of the supply and return holes.
- Use a 18mm drill bit and drill 2 holes side by side. Then use a sharp wood chisel to square off the hole. This will allow the 12mm pipe bend support to be located within the cut channel.
- Next, vacuum the whole area, especially the grooves in the tracked panels, to remove all debris.

Pipe Loop Installation

- Attach the first loop to the manifold at the supply connection.
- If the tails feed from under the floor, feed the pipe through the joist space before attaching to the manifold.
- Fit and position the bend support to the pipe where it rises out of the floor void to connect to the manifold.
- If feeding pipe tails from beneath the floor, connect another bend support to the pipe where it rises out of the floor void to enter the Tignum panels.
- Next, walk the pipe into the groove.
- Hard soled boots or shoes are recommended.
- If the pipe does not snap completely into the groove, first check to see if there is any obstruction under the pipe. If not use a rubber mallet to tap the pipe into place.
- Run the pipe to the return manifold connection and fit pipe bend supports as before.
- Repeat the procedure for all loops connected to this manifold.
- After loops have been installed the Tignum panels can be screw fixed to the subfloor.

Tignum Chipboard Panel Outputs

Pipe specification:
12mm O/D PEX

Floor construction:
Timber Panel System

Floor decking:
Either 25mm gypsum boards or 12mm plywood capping layer
Water temp drop [K]: 10

Mean water temp MWT °C	Design room temp Rt °C
35	16
	18
	20
	22
40	24
	16
	18
	20
45	22
	24
	16
	18

Inspection

Once the pipes have been laid, it is important to inspect the system before laying the floor, to ensure the installation is correct and pipes are held firmly away from any possible damage.

Pressure Testing

Once all the pipes have been laid and connected to the manifold, fill and pressure test the system.

Decking

The area should be decked, or covered, immediately to protect the system. Foot traffic must be prohibited until this is carried out to protect the pipes and panels. The final floor deck, and/or floor covering, should be installed as per the manufacturer's/supplier's instructions.

Pipe pitch, Vz [mm]			
150			
Floor covering resistance, R λ,β [m² K/W]			
0.01	0.05	0.1	0.15
Heat emission, q [w/m²]			
68.1	56.8	49.2	42.9
60.5	50.5	43.7	38.1
52.9	44.1	38.2	33.3
45.3	37.7	32.7	28.5
37.4	31.2	27	23.6
86.8	72.4	62.7	54.6
79.3	66.1	57.3	49.9
71.8	59.9	51.9	45.2
64.3	53.6	46.4	40.5
56.8	47.3	41	35.7
105.4	87.9	76.1	66.3
97.9	81.7	70.7	61.7
90.5	75.5	65.4	57
83.1	69.3	60	52.3
75.6	63	54.6	47.6
Exceeds 70 W/m² limit			

Tignum 12 Mounting Instructions

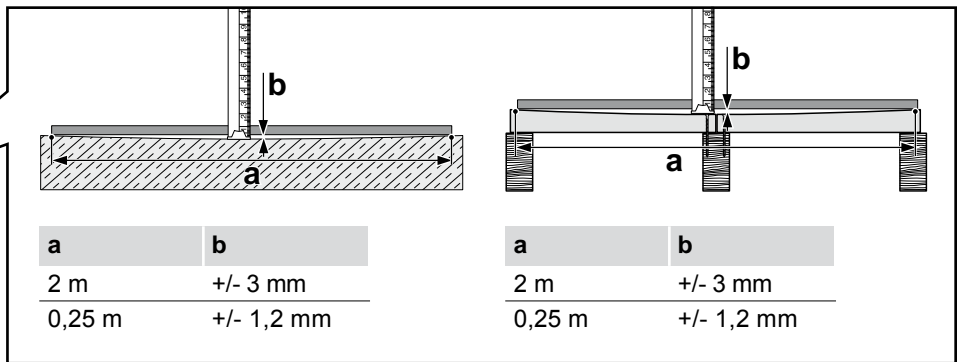
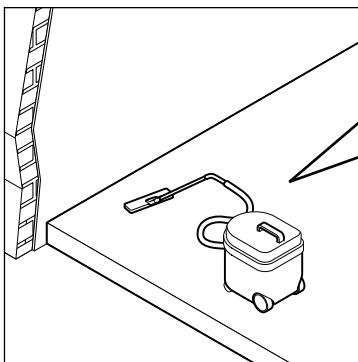
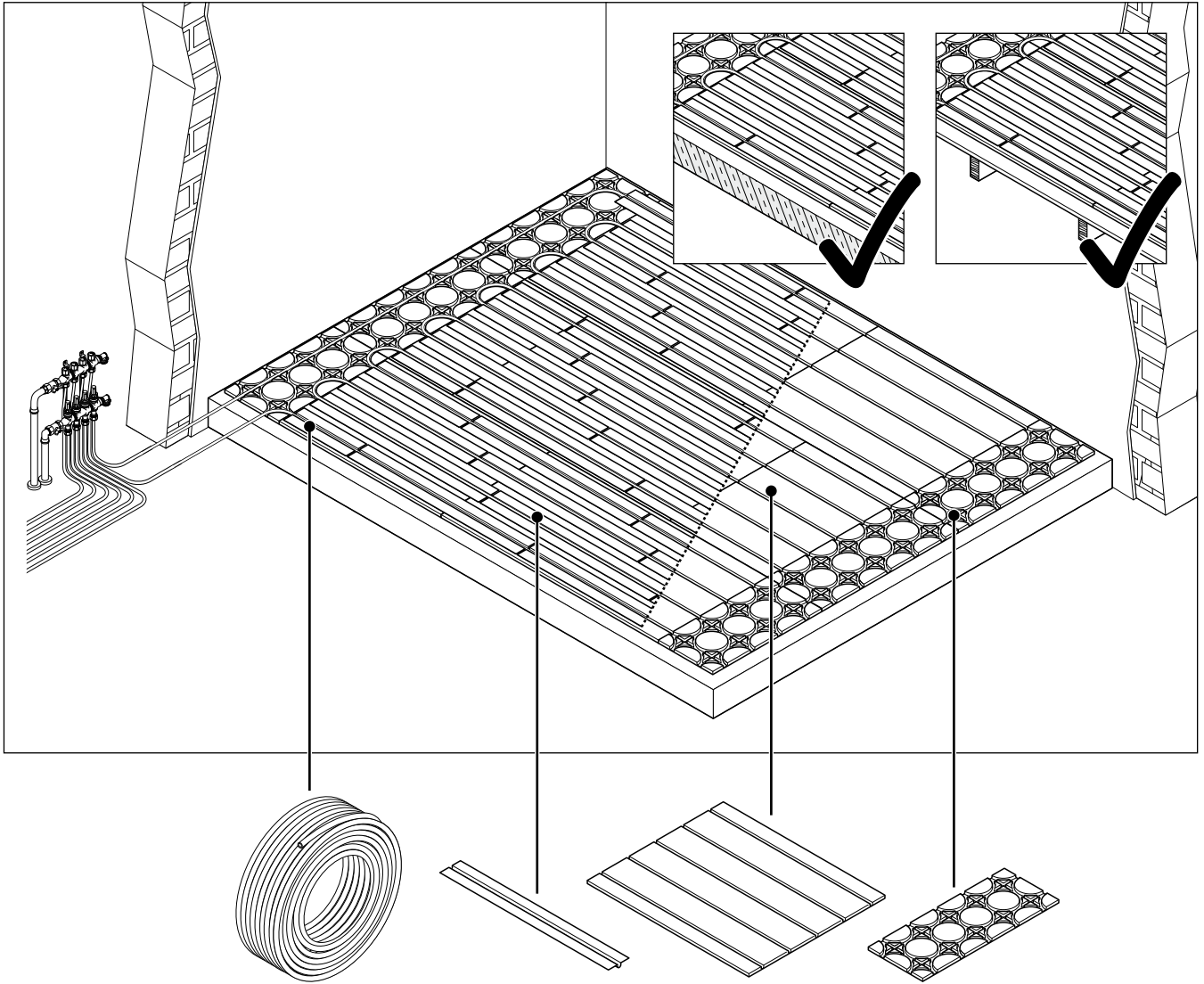

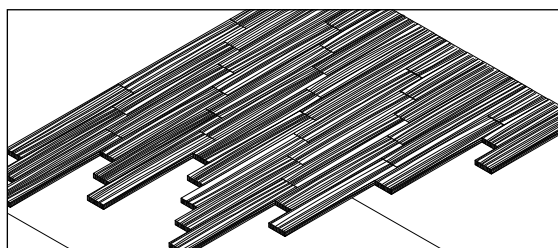
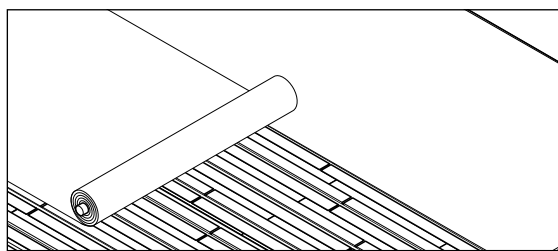
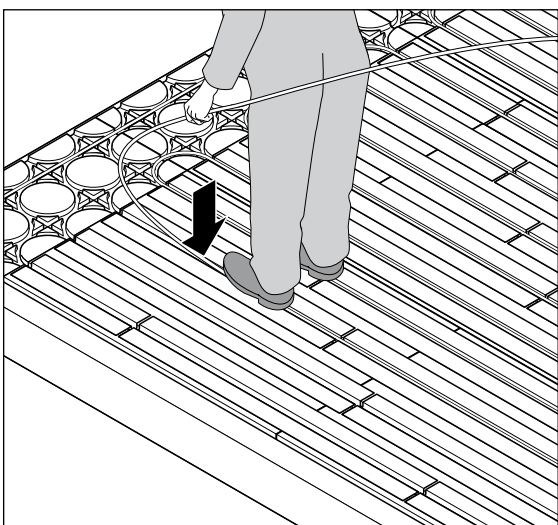
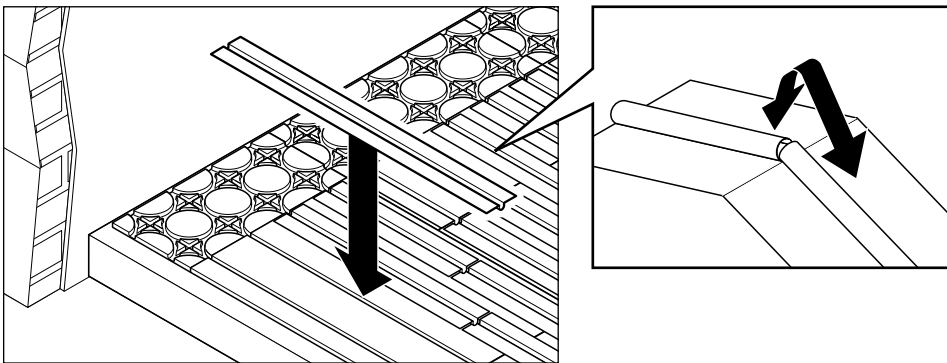
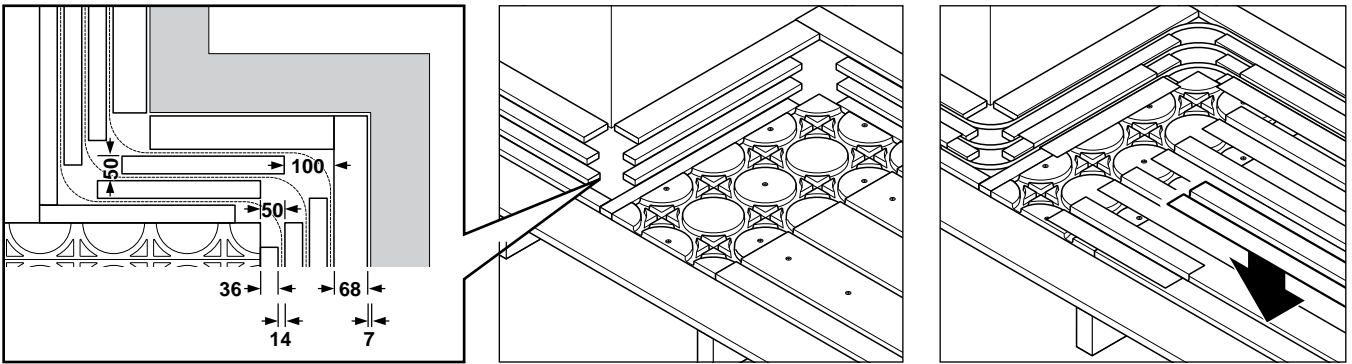
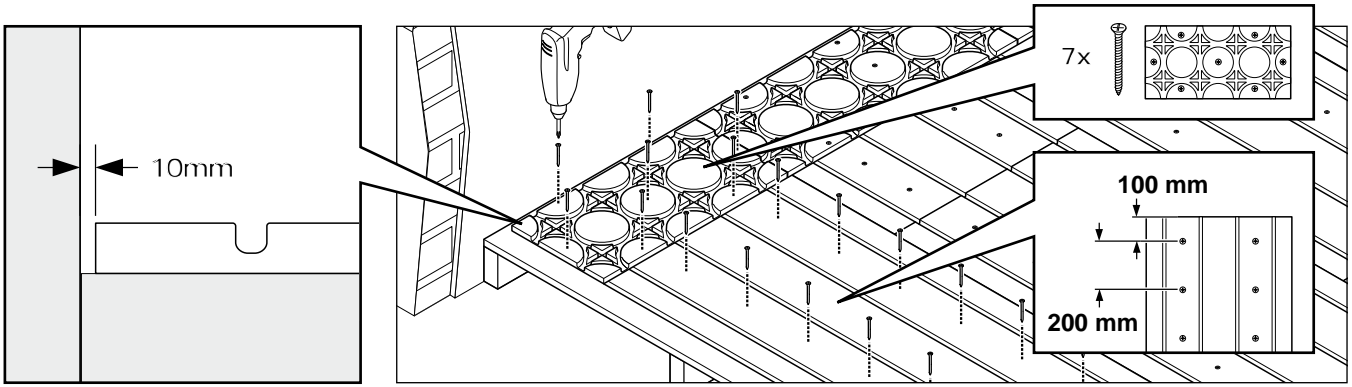

Product News

Tignum 12

Underfloor Heating System

Uponor are very pleased to announce the launch of its greatly improved Tignum 12 underfloor heating system.

Ideally suited for both new build and renovation projects, the system offers installers a high performance, low mass, low build height solution, that's only available from Uponor.

Other unique 'low build' height systems from Uponor include the Minitec and Siccus 12 ranges. All three offer a wide range of installation options to suit a variety of project requirements.

Features and Benefits

- Fast response
- High comfort levels
- 15mm panel thickness
- Preformed 12mm pipe grooves
- No joints below the finish floor
- Dry trade system
- Multiple directional turn panels
- Snap point heat emission plates
- Reduced product inventory
- Ideal for renovation and new build projects





Water Temperature Control

Selection advice and installation guidance for your chosen water temperature control solution.

Fluva T Push 12	42	VPG & PPG pump group	48
Vario B Compact control pack V5	46	Smatrix Move/Move PLUS	51

Water Temperature Control - Push 12

Pipe Dimensions	9.9mm PEX	✓	12mm PEX	✓	16mm PEX	✓	16mm MLC	✓	20mm PEX	✓
-----------------	-----------	---	----------	---	----------	---	----------	---	----------	---

Water Temperature Control for Underfloor Heating in one room

The Uponor Push 12 has been specially developed for small areas of underfloor heating in one room. It is designed to connect directly to the existing radiator system pipe work and supply one or two underfloor heating loop.

The Uponor Push 12 is designed to ensure that both the room temperature and the flow water temperature are maintained at a set level. A valve with 230V thermostatic head is opened/closed by wired or radio room thermostat and controls the water temperature in the underfloor heating system to suit the requirements of the room. Uponor recommend the use of Smatrix X-161 radio controller with Push 12, however, 230V wired thermostats can also be used. An additional thermostatic valve is built into the pump housing to limit the temperature of the flow water in the underfloor heating loop. This special design ensures that both the room temperature and the flow water temperature are maintained at a set level.

The water temperature in the underfloor heating loop must be lower than the water temperature in the radiator system. In order to obtain the required heat output, the flow in the underfloor heating loop must be greater than that in the radiator circuit. The Uponor Push 12 increases the water flow and controls the water temperature in the underfloor heating loop.

Installation

The Uponor Push 12 has been specially developed for use in conjunction with an existing radiator heating system, connecting directly to the existing pipework. It is supplied factory set for a two pipe system, but can easily be adapted to a single pipe system - see installation and operating instructions.

In order to minimise any noise in the Uponor Push 12, the maximum recommended pressure drop in the valve should not exceed 30 kPa. Uponor recommend that, if the underfloor heating loop is to be installed in a bedroom or a bathroom, then the Push 12 should be fitted outside the room itself.

Maintenance

The Uponor Push 12 generally requires no maintenance. However, as a precaution it should be regularly inspected for leaks, and checked to ensure that the pump is not making any unusual noise. Excessive noise may be caused by air getting into the heating system. This can usually be resolved by turning the pump off, allowing the system to settle and then purging it of air through the air bleed valve before re-starting it. Should the pump be inoperative for any length of time, check that the impeller on the pump is able to rotate freely by starting and stopping the pump several times. During the summer months, the pump should be inspected and run at least once a week, in order to ensure that it remains in good working order.



Product Code

Item	Code
Push 12	1067388
2 loop branch set	1005675
Vario fill & drain valves	1061802
9.9mm PEX adapter	1013426
12mm PEX adapter	1065282
16mm PEX adapter	1057441
16mm MLC adapter	1058090
20mm PEX adapter	1065290
X-161 room controller c/w:	
Dial radio thermostat	1071680
Digital radio thermostat	1071692
Programmable radio stat	1071672

Selection Guide for 9.9mm Minitec & 12mm Pex, m²

	Output (Wm ²)		
	100	70	50
Maximum Loop Length (m)			
9.9mm Minitec	50	70	85
12mm PEX - Floating	N/A	65	80
Timber Panel	N/A	55	70
Maximum Floor Area (m²)			
9.9mm Minitec	8.5	12	17
12mm PEX	N/A	15	20

Note: 9.9mm Minitec at 12°C dT & 100mm c/c
System12 Floating Floor at 10°C dT & 125mm c/c
System12 Timber Panels at 10°C dT & 150mm c/c

Selection Guide for 16mm Pex, m²

	Output (Wm ²)		
	100	70	50
Maximum Loop Length (m)			
60	80	100	
Maximum Floor Area (m²)			
10	15	20	

Note: Areas based on 2 pipe loops laid at 200mm c/c & dT of 10°C

Selection Guide for 16mm MLC, m²

	Output (Wm ²)		
	100	70	50
Maximum Loop Length (m)			
50	75	100	
Maximum Floor Area (m²)			
20	25	30	

Note: Areas based on 2 pipe loops laid at 200mm c/c & dT of 10°C

Selection Guide for 20mm Pex, m²

	Output (Wm ²)		
	100	70	50
Maximum Loop Length (m)			
60	80	100	
Maximum Floor Area (m²)			
17	23	29	

Note: Areas based on 2 pipe loops laid at 300mm c/c & dT of 10°C

1

Uponor Push-12-AC

1067388

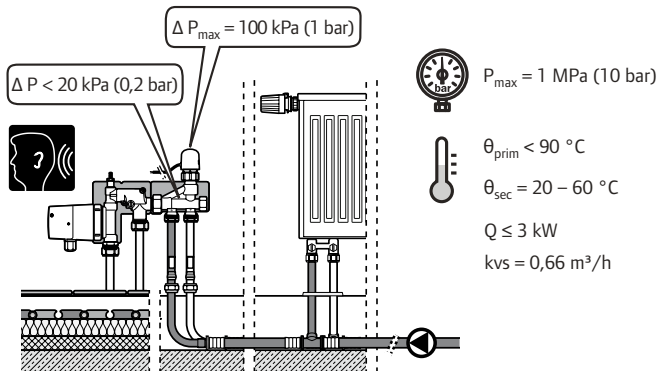
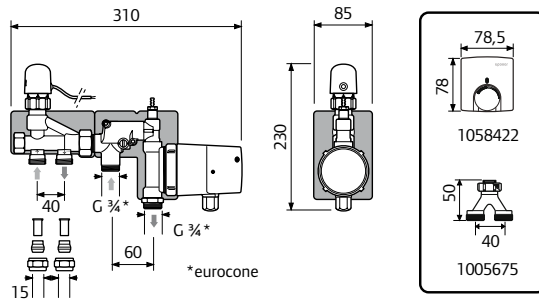

2

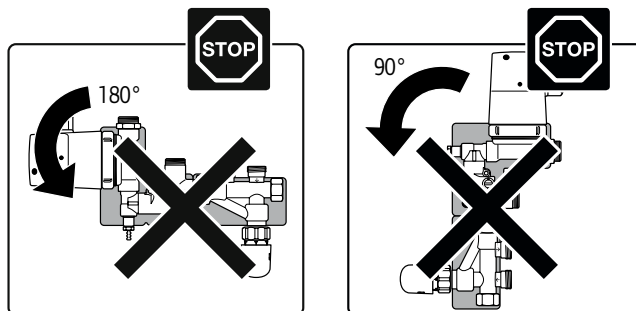

2.1

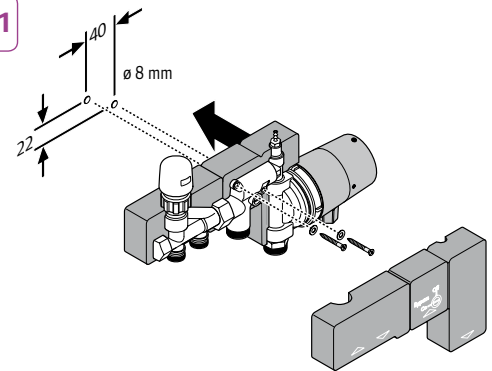

2.2

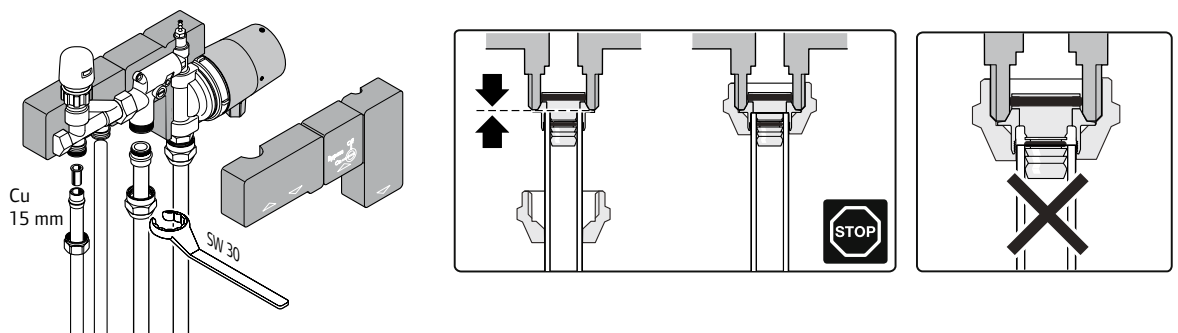

3

Uponor Push-12 230V

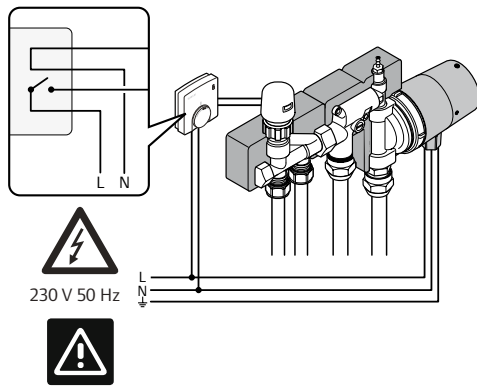

Uponor Push-12 AC - Radio

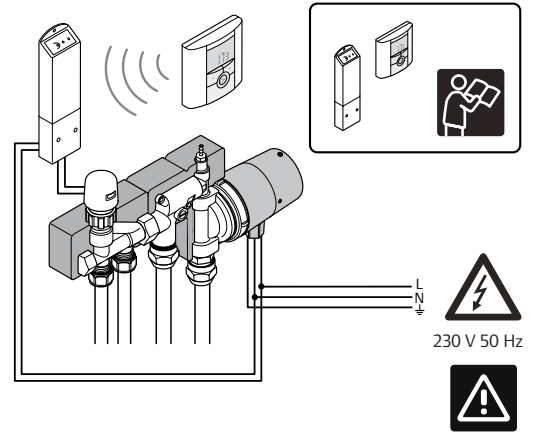

4

Uponor Push-12-AC

4.1

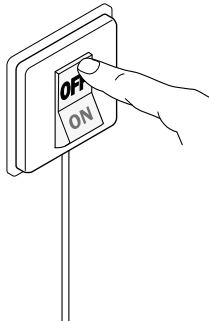

4.2

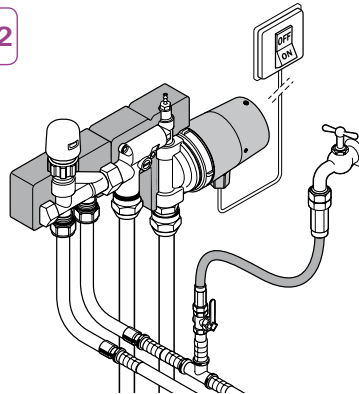

OPTION

1061802

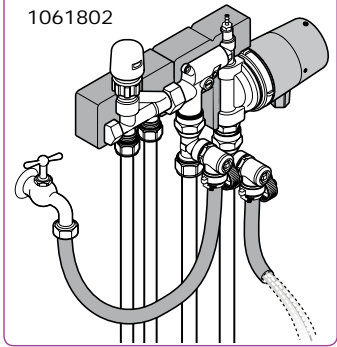

4.3

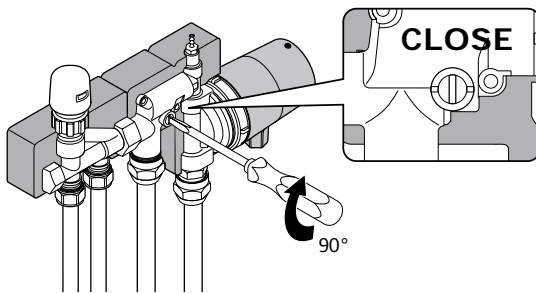

4.4

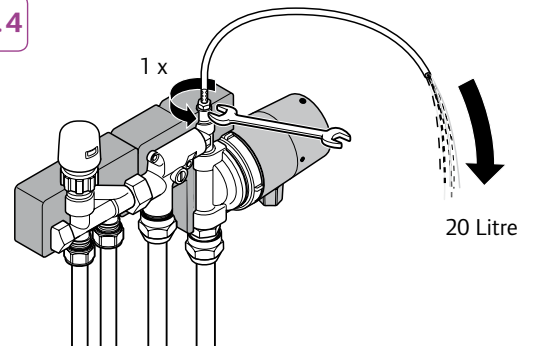

4.5

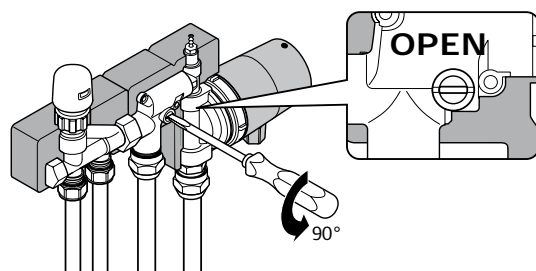

4.6

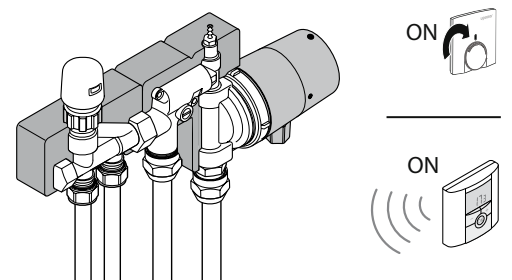

5

5.1

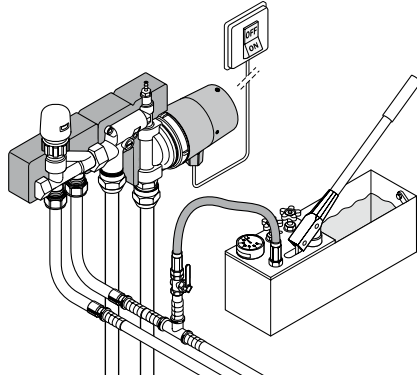

6 bar ≥ P ≥ 4 bar

5.2

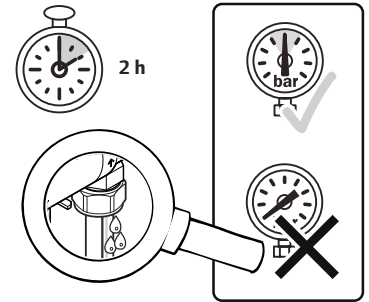

5.3

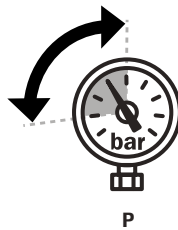

5.4

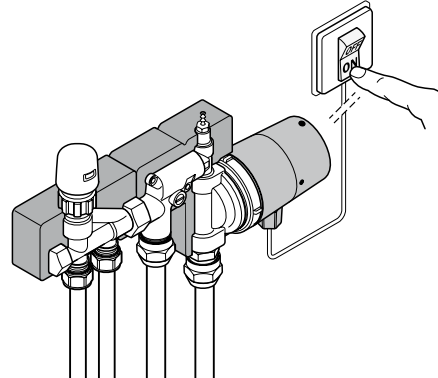

6

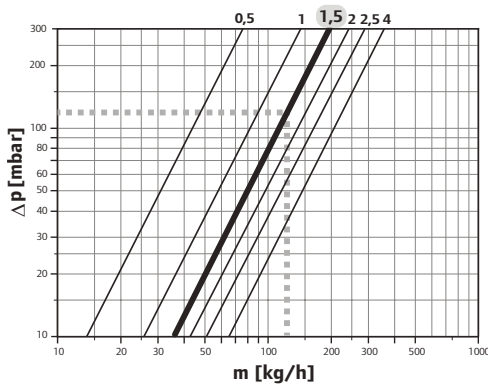

2. open 1,5x

SW 10

1. max close

Turns	0,5	1,0	1,5	2,0	2,5	4,0	open
kv	0,14	0,27	0,38	0,46	0,54	0,65	0,66

7

% flow	0	15	20	25	30	35
Turns	closed	1	1,5	2	3	open
kv	1,25	1,45	1,5	1,55	1,65	1,8

max: 1-pipe system

SW 4

max: 2-pipe system

Water Temperature Control - Compact Control Pack V5

Pipe Dimensions	9.9mm PEX	✓	12mm PEX	✓	16mm PEX	✓	16mm MLC	✓	20mm PEX	✓
-----------------	-----------	---	----------	---	----------	---	----------	---	----------	---

Installation Instructions

To reduce on site installation time the Uponor Compact Control Pack V5 is available pre-assembled to the Uponor TM Manifold (2-8 port). The following is intended to give the installer the necessary information to install the V5 Compact Control Pack when bought in its preassembled form. If a Compact Control Pack (CCP) and Manifold are purchased separately then the installation instructions included with the CCP should be consulted prior to installation.

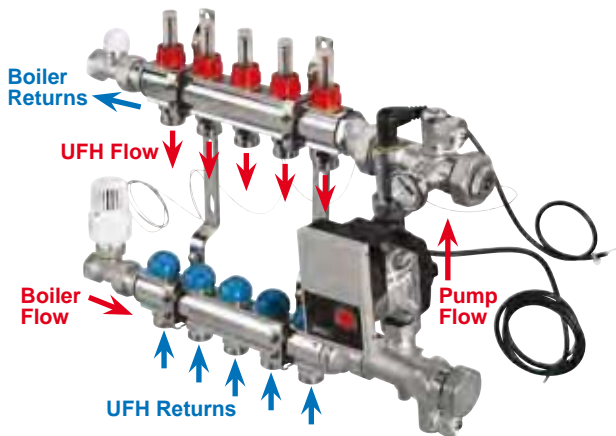

Pack Contents

Main items:

- 1" Wilo 6m A - rated pump
- Thermostatic head and pipe sensor
- Preset immersion thermostat
- 2-port thermostatic valve body, 1" MT x 3/4" FT (BSP)
- Lockshield valve, 1" MT x 3/4" FT (BSP)
- Thermometer
- Manifold
- 1" connection set with integral pump isolation valve
- 1" connection set with immersion sensor pocket.
- 2 x fill and drain points

Note, The pack does not include fittings to go from the manifold on to the UFH pipe work. These need to be ordered separately. The fittings used will have to be suitable for the pipe size and pipe type used.

Introduction

- The Uponor Underfloor Heating (UFH) Compact Control Pack is a "designed for purpose" solution for controlling the flow and temperature of water in systems with up to 200m² of active floor area and maximum 15kW heat load.
- The Control Pack comes pre-assembled on to the Uponor TM Manifold and is ready to be mounted on the wall straight from the box. It can also be supplied alone for coupling to LS manifolds and the larger size, 9 loops or more, TM manifolds.
- The thermostatic valve has a control head with a temperature adjustment range of 20 - 65°C.

Operation

• During Heating Demand Periods

The Compact Control Pack is designed to mix the primary boiler flow water with the under floor heating return water. This is managed via a two port injection valve which is situated on the boiler flow which when open, allows the higher temperature boiler flow water to blend with the UFH return water in the return manifold. This maintains the required UFH flow temperature. An internal pipe sensor is fitted within the 90° elbow which operates the two port thermostatic injection valve.

A secondary pump then circulates the water around the UFH loops. To ensure that the majority of the water is forced around the UFH pipe network, a lock shield is positioned on the return back to the boiler which is used for balancing the system.

• High Limit Protection

The Compact Control Pack also includes a failsafe device. A high limit thermostat which is fitted to ensure that water exceeding 60°C does not flow around the UFH system as per BS EN: 1264 since high temperature water may damage floor coverings. This thermostat will operate, in the unlikely event of a high water temperature condition, to switch off the electrical supply to the UFH pump therefore preventing overheating and possible damage to the floor.

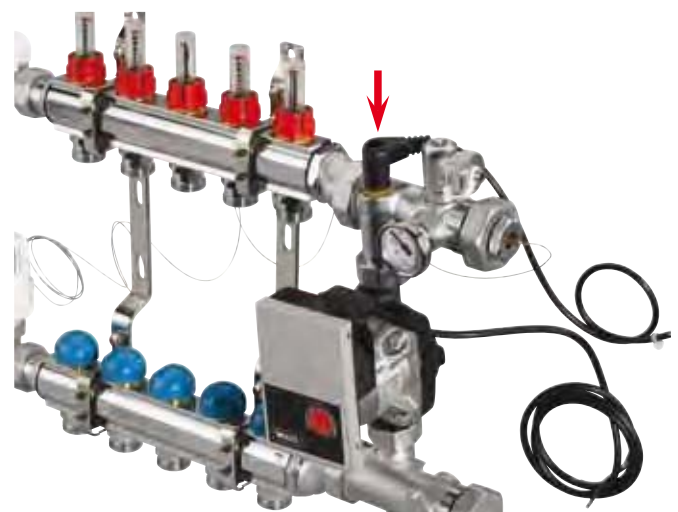

Approach temperature from heat source must be a minimum of 15°C above the required design flow temperature.

Installation

- The unit is ready to be wall mounted straight from the box. Appropriate wall plugs and fixing screws should be used to do this. If there is not 100mm available to the right of the UFH pump then it is recommended that the injection valve head and immersion sensor are fitted prior to wall mounting the unit as per picture below.



- Fit the injection valve head on to the injection valve on the bottom left of the unit. The immersion sensor needs to be fitted into the pocket above on the connection set above the UFH pump. The grub screw should be tightened to ensure the sensor can not move.

Note, it is possible to install the CCP V5 for either left or right hand primary pipe connection.

- Primary flow & return pipes, to supply the UFH manifold, should be sized correctly, based on flow rate, pressure loss, and available pump duty. However, as a general guide we suggest the following sizes:

Manifold Size	MLC/PEX (mm)			Copper (mm)		
	9.9/12	16	20	9.9/12	16	20
2 loop	16	16	16	15	15	15
3 loop	16	16	20	15	15	15
4 loop	16	20	25	15	15	22
5 loop	16	20	25	15	22	22
6 loop	20	25	25	15	22	22
7 loop	20	25	25	22	22	28
8 loop	20	25	32	22	22	28
9 loop	20	25	32	22	28	28
10 loop	25	32	32	22	28	28
11 loop	25	32	32	22	28	28
12 loop	25	32	32	22	28	28

Wiring

- A suitable electrical supply is required.
- The immersion thermostat must be wired into the control circuit to cut out the electrical supply to the UFH circulator and two port zone valve in the event of a high limit condition.
- For individual room control systems the manual heads on the lower manifold are replaced with electro-thermal actuators. Uponor can supply various wiring/relay control units, including wireless control versions, to simplify the wiring for these types of installations.
- Uponor recommends that a 2-port motorised valve is used on the primary flow feeding the UFH manifold, a 'demand' from the UFH system will open the zone valve and the auxiliary switch should be wired to energise the boiler and main system circulator.
- All wiring should be in accordance with the current edition of the IEE Regulations and any applicable Local Regulations.

- Refer to Mechanical and Electrical Schematics chapter for wiring drawings.

Settings

- The thermostatic head is set to the required water flow temperature for the underfloor heating system, typical settings as follows:
Screed floors: 40 – 45°C
Wooden floors: 50 – 55°C
- The high limit thermostat does not need any adjustment. It is preset to 60°C.
- The lockshield valve needs to be opened so that it forces the majority of the water around the UFH system. The primary and secondary pump speeds, existing primary pressure and manifold size will affect how far open the lockshield valve needs to be.
 - To make an adjustment first unscrew and remove the white cap. Use the included Allen Key to adjust the valve.
 - To calibrate it is recommended that the lockshield valve is first fully closed and then opened until you see the thermometer continuously reading the same temperature as the setting on the injection valve head.
- Adjust the circuit flow rates by adjusting the flow regulators (⌵, meters) - see Starting-up and System Operation chapter.
- Pump setting: Set to maximum.

Duty Table - Vario B Compact Control Pack V5

Heat Output (Wm ²)					
100	70	50			
Mintec PEX 9.9 Maximum Loop Length (m)					
80	100	120			
Maximum Floor Area (m ²)					
100	120	120			
PEX 12 Floating Max Loop Length (m)					
	100	120			
PEX 12 Tignum Panel Max Loop Length (m)					
	90	110			
Maximum Floor Area (m ²)					
	120	120			
PEX 16 Maximum Loop Length (m)					
80	100	120	120		
Maximum Floor Area (m ²)					
140	200	145	200		
MLC 16 Maximum Loop Length (m)					
75	100	120	120		
Maximum Floor Area (m ²)					
140	200	140	200		
PEX 20 Maximum Loop Length (m)					
80	100	100	120	120	160
Maximum Floor Area (m ²)					
150	125	200	180	200	200

Note:

- 1) Pipes laid at 100mm c/c and dT = 12K for **Mintec** 9.9mm pipes.
- 2) Pipes laid at 150mm c/c and dT = 10K for **PEX 12** Timber Panel System.
- 3) Pipes laid at 125mm c/c and dT = 10K for **PEX 12** Floating Floor.
- 4) Pipes laid at 200mm c/c and dT = 7.5K for **PEX 16/MLC 16** pipes.
- 5) Pipes laid at 300mm c/c and dT = 7.5K for **PEX 20** pipes.

Water Temperature Control - VPG & PPG Pump Group

Pipe Dimensions	9.9mm PEX	✓	12mm PEX	✓	16mm PEX	✓	16mm MLC	✓	20mm PEX	✓
-----------------	-----------	---	----------	---	----------	---	----------	---	----------	---

Introduction

- The pre-assembled sets are designed for control of both water temperature and flow rates in secondary UFH circuits. All sets are robust and engineered for use in new and old domestic and commercial applications. The range of three sets gives flexibility to match individual project duties without compromising performance.
- The sets are supplied for left-hand primary connections. The VPG-10 can be handed by removing the brackets and rotating the pump through 180°. Right hand installation for PPG-20 is possible.
- Please read these instructions completely before commencing installation, this will reduce both initial setup and commissioning time.

Set Contents

- Wilo A-Rated energy efficient pump
- 1" Ball valves with butterfly handles
- Brass interconnecting piping
- Mounting brackets
- Rubber lined pipe clips
- 1" Brass manifold ball valve connection set
- Manifold bracket spacer set
- Excenter fittings for direct manifold coupling (PPG-20)
- Secondary water temperature immersion pocket (PPG-20)
- DUOmix TMV with electro-thermal actuator (VPG-10 only)
- 3-port rotary shoe valve (PPG-20)

Note: Move controller and 230V valve actuator for PPG-20 sold separately.

VPG-10 with actuator (1061091)



PPG-20 (1059839)



VPG and PPG Installation

- For future reference record the set name and batch number found on the box label.
Set Product Name: _____
- In a majority of cases and as recommended, these instructions have been written assuming that the UFH manifold and VPG/PPG set will be coupled together..
- All fittings, except the pump unions, compression nut, brackets and manifold connectors, are supplied sealed with liquid thread sealing compound.
- **When tightening fittings to the sets always ensure the liquid sealed components are sufficiently restrained to prevent rotation and breaking of thread seals.**
- Identify all components and ensure adequate space for mounting the set is provided.
- The PPG set is supplied at a pitch of 175mm and comes with excenter fittings that enables direct coupling to the UFH manifolds which have a pitch of 225mm. The VPG-10 however is supplied at a pitch of 225mm and does not require any additional fittings.

Please follow the installation procedure below:-

- Apply thread sealant to the 1" BSPM end of the manifold connection sets and fit to the manifold ball valves.
- Remove the plastic dust caps from the manifold connections of the VPG/PPG and offer the VPG/PPG assembly up to the manifold and mark the bracket fixing locations.
- Lay the VPG/PPG aside and prepare the wall fixings, (not supplied), then fix the VPG/PPG to the wall.
- Insert the fibre washers between the manifold connection set flanges and the VPG/PPG and tighten the swivel nuts.
- Ensure the pump shaft is horizontal by loosening and retightening the pump unions. See pump installation instructions for further details.

VPG-10, DUOmix Actuator Installation

- Prior to fitting the valve actuator, the temperature setting of the TMV requires adjusting using a 10mm spanner.
- The fully down/clockwise rotated position corresponds to the minimum temperature setting of 35°C, and the fully up/anticlockwise rotated position corresponds to the maximum setting of 60°C.

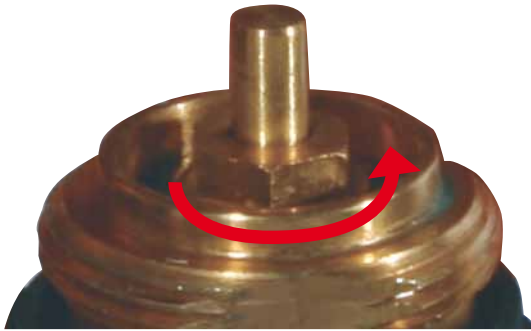

- For intermediate temperature settings rotate the nut anticlockwise from the fully down position through an angle of 60° (one nut flat) for approximately every 4°C temperature rise required, see table below.

Rotation from fully closed (60° is one nut flat)						
0°	60°	120°	180°	240°	300°	360°
35	39	43	48	52	56	60
Approx. mixed flow temp. °C						

- Typically, the maximum water temperature setting for solid floors is 45°C and 60°C for timber suspended and floating floors.
- To install the actuator, position over the valve head and apply a downward pressure to compress the pin and hand tighten the actuator swivel nut. The primary hot port is now in the closed position until the actuator is energised, as shown by the actuator indicator.



Remote Coupling of Set and Manifold(s)

- The set can be used for supplying mixed water to a remote manifold(s).
- Like the primary system, the correctly sized interconnecting pipe size between the set and manifold(s) is essential for satisfactory operation of the UFH system.
- The area served by a set, as given in the Selection Guide, will be reduced when remotely coupling the mixing set and

PPG-20, Motorized Valve Actuator Installation

- The PPG-20 is designed for use with the Move Controller X-157 (product code 1071693) and 230V valve actuator (product code 1002357); both are ordered and supplied separately.
- Set the valve shaft in the mid-position of the scale plate, between the 9 and 12 o'clock position, and remove the handle without changing the position of the valve spindle.
- Place the white sleeve on the spindle.
- Screw the actuator ant-rotation stud into its position beneath the valve cover plate.



- Fit the actuator to the valve by removing the actuator knob, and securing together with the central screw. Refit knob back on the actuator - red line indicator should be pointing to the 3 o'clock position.
- Fit the red plastic scale to the actuator cover directly above the knob. Use the one with the larger scale to the left-hand side.
- Should manual operation of the valve be required simply pull and twist the knob in the desired direction.



- manifold(s), as some of the pump head will be used to overcome the interconnecting pipe pressure loss.
- For further advice on remote coupling and interconnecting pipe sizes please refer to the Uponor Technical Department (See telephone number on back page).

Duty Table - VPG-12-TH Pump Group

Heat Output (Wm ²)					
100	70	50			
Minitec PEX 9.9 Maximum Loop Length (m)					
80	100	120			
Maximum Floor Area (m ²)					
100	120	120			
PEX 12 Floating Max Loop Length (m)					
	100	120			
PEX 12 Tignum Panel Max Loop Length (m)					
	90	110			
Maximum Floor Area (m ²)					
	120	120			
PEX 16 Maximum Loop Length (m)					
80	100	120	120		
Maximum Floor Area (m ²)					
130	185	140	260		
MLC 16 Maximum Loop Length (m)					
75	100	120	120		
Maximum Floor Area (m ²)					
130	185	115	260		
PEX 20 Maximum Loop Length (m)					
80	100	100	120	120	160
Maximum Floor Area (m ²)					
130	120	185	170	260	160

Duty Table - PPG-20 Pump Group

Heat Output (Wm ²)					
100	70	50			
PEX 16 Maximum Loop Length (m)					
80	100	120	120		
Maximum Floor Area (m ²)					
175	250	185	350		
MLC 16 Maximum Loop Length (m)					
75	100	120	120		
Maximum Floor Area (m ²)					
175	250	155	350		
PEX 20 Maximum Loop Length (m)					
80	100	100	120	120	160
Maximum Floor Area (m ²)					
175	160	250	230	350	300

Note:

- 1) Pipes laid at 100mm c/c and dT = 12K for **Minitec** 9.9mm pipes.
- 2) Pipes laid at 150mm c/c and dT = 10K for **PEX 12** Timber Panel System.
- 3) Pipes laid at 125mm c/c and dT = 10K for **PEX 12** Floating Floor.
- 4) Pipes laid at 200mm c/c and dT = 7.5K for **PEX 16/MLC 16** pipes.
- 5) Pipes laid at 300mm c/c and dT = 7.5K for **PEX 20** pipes.

Typical VPG/PPG Plumbing Schematic

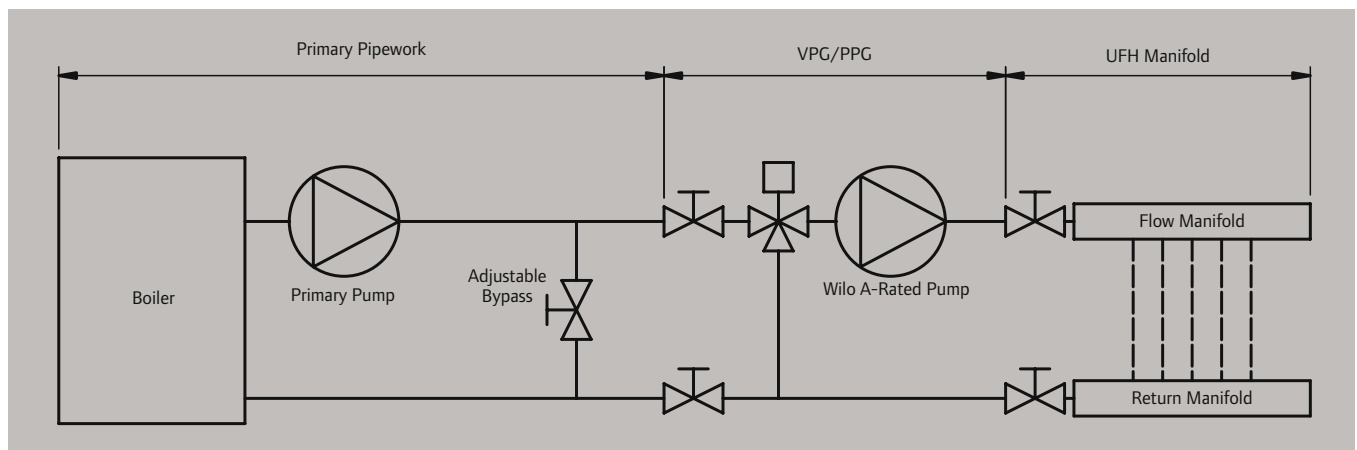

Water Temperature Control - Smatrix Move/PLUS Controller

Pipe Dimensions	9.9mm PEX	✓	12mm PEX	✓	16mm PEX	✓	16mm MLC	✓	20mm PEX	✓
-----------------	-----------	---	----------	---	----------	---	----------	---	----------	---

The Smatrix Move/Move PLUS Controller is flexible, easy to install, simple to operate and designed to achieve optimum results.

The Smatrix Move/Move PLUS Controller

- A fixed water temperature controller
- A weather compensator
- Suitable for heating only applications
- Suitable for combined heating and cooling applications (Move PLUS X-158 only)
- Able to work stand alone (with supplied sensors)
- Able to operate in an intelligent way with Smatrix room controls for heating and cooling changeover (Move PLUS only).
- Able to co-operate in an integrated and enhanced way with the Smatrix range of room temperature controls.

The Uponor Smatrix Move/Move PLUS Controller is a piece of advanced technology, yet simplifies the installation task and is intuitive for the end user.

Once connected, the installation wizard guides you through the system set-up. By following the on screen instructions it is configured in almost no time.

And it won't take long to instruct your customer, either! The quick menu makes it easy to find the settings and handle the Uponor Smatrix Move/Move PLUS.

- Control of DHW demand via third party cylinder stat and motorised valve.
- 2 x general purpose inputs and 2 x general purpose outputs.
- Separate pump connection terminals.
- Installation wizard and quick menu system.
- ECO/Comfort timer with automatic summer/winter time change.
- Holiday mode.



Uponor Smatrix Move controller



Uponor Smatrix wireless thermostat

Pack Contents

Move X-157: Controller, outdoor sensor and supply water sensor (Product Code: 1071693).

Move PLUS X-158: Controller, outdoor sensor, supply water sensor, antenna and T-168 programmable thermostat (Product Code: 1071656)

Note: X-157 can be upgraded to X-158 with addition of external antenna and wireless thermostat.

In the majority of installations, heating with outdoor controlled supply (commonly known as weather compensation) will be the chosen operating mode. For this arrangement all required sensors are contained in the standard Move Controller X-157 pack. To gain maximum benefits of energy efficiency and communication between water and room temperature controls, use the Move Controller to interface with Uponor Smatrix range of room temperature controls.

Smatrix Move/Move PLUS - Quick Guide



NOTE!

This is a quick start guide to serve as a reminder for experienced installers. We strongly recommend reading the full installation and operation manual before installing the control system.



WARNING!

Electrical installation and service behind secured 230 V AC covers must be carried out under the supervision of a qualified electrician.

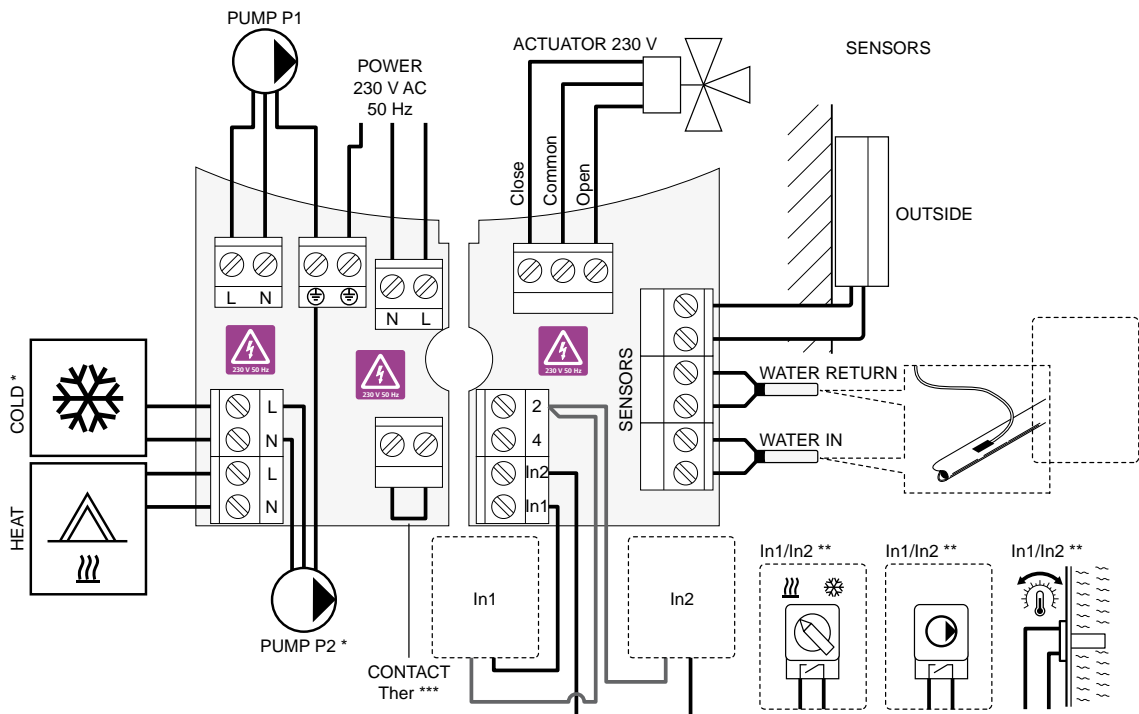

*) Connect either COLD or PUMP P2 (secondary heating/cooling circuit) to connection terminal.

**) Select one of the inputs (heating/cooling switch, pump control signal, or immersion thermostat) and set parameter 11 – Wired Input 1 selection, or parameter 12 – Wired Input 2 Selection, accordingly. The heating/cooling option can only be used in systems without a registered wireless thermostat

***) Optional temperature limiter connection, factory fitted with cable bridge.. Remove the bridge if a temperature limiter is to be used together with PUMP P1.

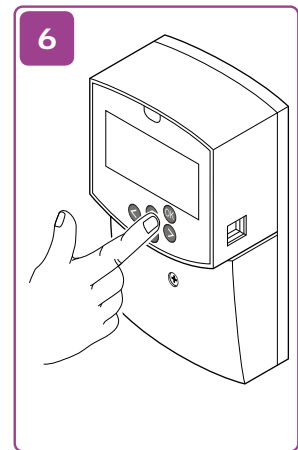
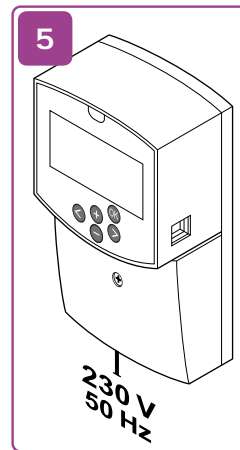
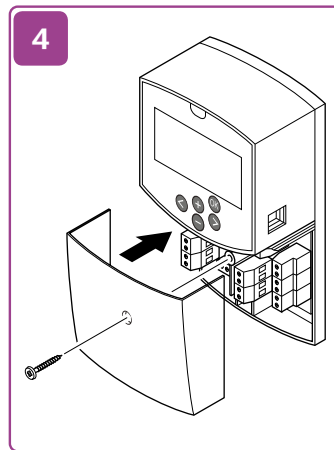
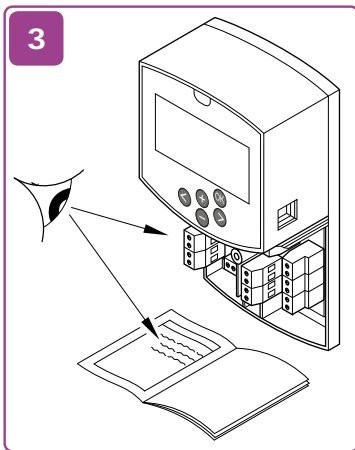
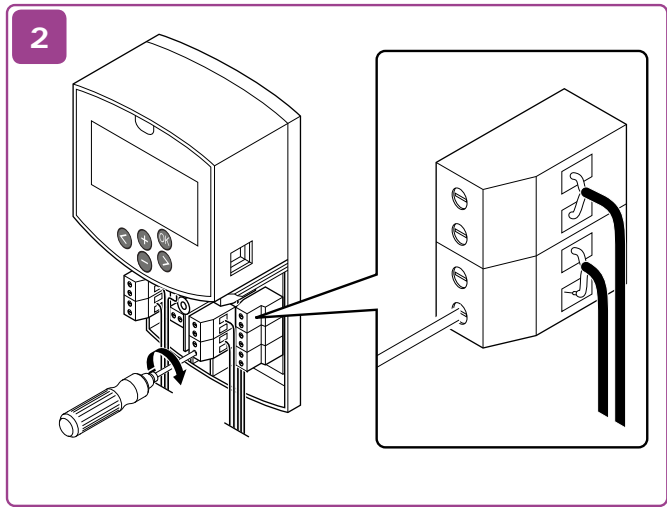
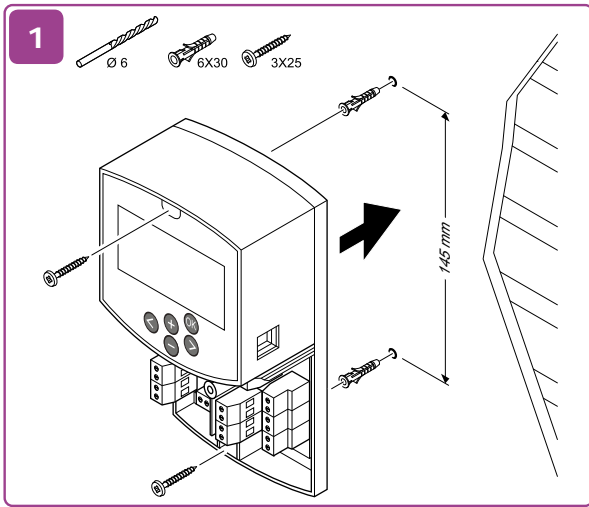

Installation

CAUTION!
Do not attempt to connect Uponor Smatrix Base thermostats to the controller. They are not suited for each other, and they may get damaged.

1. Attach the controller to the wall by using wall screws and plugs.

If the controller is installed inside a metal cabinet, then locate the antenna outside the cabinet.
2. Connect additional equipment, such as actuator(s), circulation pump(s), temperature sensors etc, and secure them with cable clamps.

3. Check that all wiring is complete and correct:
 - Actuators
 - Heating/cooling switch
 - Circulation pump(s)
 - Temperature sensors
4. Ensure that the 230 V AC compartment of the controller is closed and the fixing screw is tightened.
5. Connect the power cable to a 230 V AC wall socket, or if required by local regulations, to a junction box.
6. Setup the system (see next page)

Setup the system

Change the system parameter settings to setup the system.

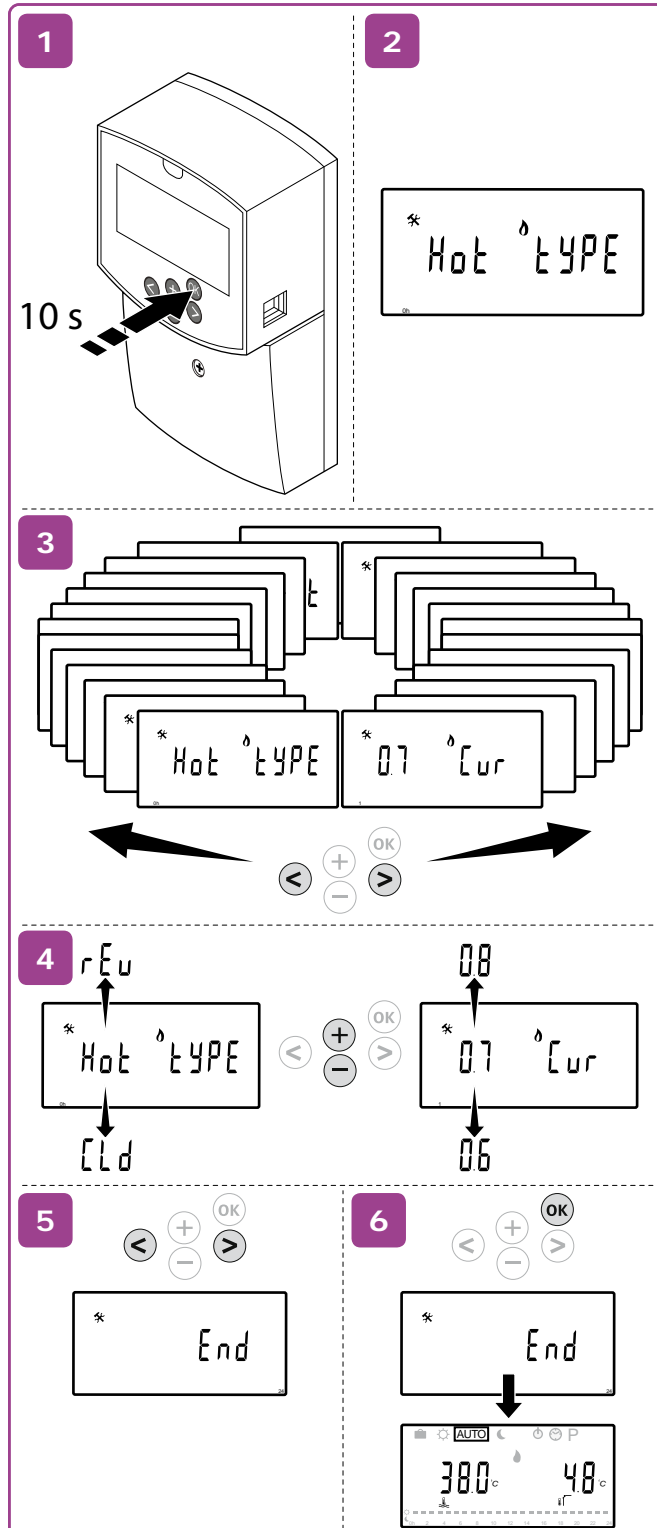

NOTE!

Some system parameter settings are only accessible during the first 4 hours after power up. This is done to prevent mistakes after installation. If the locked system parameter symbol  is displayed, the power to the controller has to be disconnected and reconnected again to modify these parameters. No settings are lost when disconnecting or after a power failure.

The settings available while in run mode are always accessible for change, and will not be locked.

To enter system parameter settings:

1. Press and hold the **OK** button for about 10 seconds.
2. The settings icon is displayed in the top left hand corner of the display, and the text **Hot type**, **Cld type**, or **rEv type** (depending of current operating mode) is displayed.
3. Use buttons **<** or **>** to locate a parameter (see list below) and press **OK**.

Some of these parameters require other parameters to activate them.

Menu	Display	Description
0	type	Type of installation (heating and/or cooling)
1	Cur	Heating curve See page 9 for more information and a diagram
2	Hi	Maximum supply temperature (heating mode)
3	Lo	Minimum supply temperature (heating mode)
1	Cur	Cooling curve See page 9 for more information and a diagram
2	Hi	Maximum supply temperature (cooling mode)
3	Lo	Minimum supply temperature (cooling mode)
4	InSt	Type of system (hydraulic installation)
5	th	Not used by Move
6	tHty	Not used by Move
7	BGAP	Boost function if the difference between the supply and return temperature is too much
8	trF1	Not used by Move

Menu	Display	Description
9	trF2	Not used by Move
10	tr1o	Not used by Move
11	in1	Wired input 1, select function
12	in2	Wired input 2, select function
13	OUSE	Outdoor sensor selection (installed/wireless/wired/etc)
14	Out	Outdoor temperature, fixed value if outdoor sensor is not installed
15	ourF	Not used by Move
16	°C	Display unit
17	00:00	Time unit (AM/PM/24H)
18	GriP	Valve and pump exercise
19	PUMP	Pump start delay after the mixer valve has closed
20	ctrl	Forced control of the actuator
21	PrH	Floor/screed preheating program
22	dry	Floor/screed drying program
23	ALL	Factory reset Press and hold the OK button for about 5 seconds
24	End	Exit system parameter settings

- Use buttons - or + to change parameter settings.
- Use buttons < or > to locate parameter **24 (End)** – Exit system parameter settings.
- Press the **OK** button to exit the system parameter settings.

Operating mode

During normal operation, the controller is in run mode.

In run mode different operating modes can be selected, as well as setting current time and day, and selecting a scheduling program.

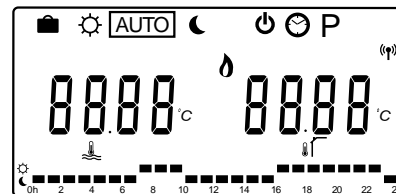

Use buttons < or > to change operating mode. A box shows which mode has been selected.

Available operating modes and settings in run mode are the following.

Icon	Operating mode
	Holiday mode
	Comfort mode
Auto	Automatic mode (default) Sets operating mode according to set scheduling program
	ECO mode
	Stop mode
	Time and day settings
P	Scheduled programs menu
	Heating/cooling mode (only available if cooling is activated) This mode requires system parameter 0 – Type of installation being set to rEv, but is hidden if system parameters 11 or 12 is set to HC.

Circulation pump

If a circulation pump is connected to the controller, it will run continuously (default setting) during normal operation.

To change this setting, go to system parameter **19 (PUMP)** – Pump start delay, in the controller.

See section Setup the system for more information.

The Move controller can receive a pump demand signal to one of the wired inputs (input 1 or 2, parameter 11 or 12 set to C_b) from another controller in the system, turning on or off the circulation pump connected to P1.

Heating and cooling curve

The heating and cooling curves for the Uponor Smatrix Move controller is shown in the diagram below. The diagram shows the calculated supply temperature, for each curve, at different outdoor temperatures. The controller uses the selected curve to operate the mixer valve, which in turn adjusts the supply temperature to the system.

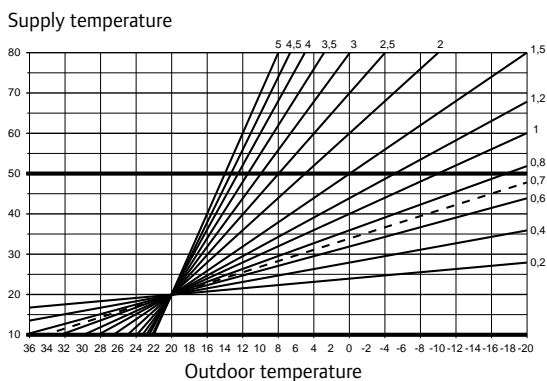

The choice of curve depends on a combination of different factors, such as how well insulated the building is, geographical location, type of heating/cooling system etc.

Example:

A poorly insulated house heated by a radiator system requires a higher curve value than an equivalent house with underfloor heating.

The curves in the diagram are also limited by maximum and minimum parameters set in the system (marked in the diagram with extra thick lines).

To change the heating and/or cooling curve:

1. Press and hold the **OK** button on the controller for about 10 seconds to enter the system parameters menu.
2. The settings icon is displayed in the top left hand corner of the display, and the text **Hot type**, **Cld type**, or **rEv type** (depending of current operating mode) is displayed.
3. Use buttons < > to locate parameter **1 (Cur)**

Heating curve:

Default: 0.7

Setting range: 0.1 – 5, 0.1 increments

Cooling curve:

Default: 0.4

Setting range: 0.1 – 5, 0.1 increments

4. Use buttons - or + to change parameter setting.
5. Press the **OK** button on the controller to confirm the change and return to the system parameter settings.
6. Repeat steps 3 through 5 to change the other curve settings, if needed.

Factory reset

To perform a factory reset, go to system parameter **23 (ALL)** – Factory reset, in the controller.

Press and hold the **OK** button for about 5 seconds until the controller restarts.

See section Setup the system for more information.

Heating & Cooling Room Controls



Uponor individual room controls, combined with our radiant heating and cooling solutions, provide comfortable ambient temperatures all year round.

Uponor Room Controls overview	58	Smatrix Space	63
Smatrix Wave	59	Smatrix Base	64
Smatrix Wave Plus	61	Base 230v	65

Uponor Room Controls overview



Smatrix Wave PLUS (Radio)	Smatrix Wave (Radio)	Smatrix Base (Wired bus)	Smatrix Space/Space PLUS (Radio)	Base (Wired 230V)
<ul style="list-style-type: none"> • Touchscreen user interface, controls upto 4 controllers and 48 zones 				
<ul style="list-style-type: none"> • Controls a maximum of 48 zones through one touchscreen interface 	<ul style="list-style-type: none"> • Controller for up to 6 thermostats and 8 actuators 	<ul style="list-style-type: none"> • Controller for up to 6 thermostats and 8 actuators 	<ul style="list-style-type: none"> • Single zone wireless control 	<ul style="list-style-type: none"> • Surface or flush mounted thermostats available
<ul style="list-style-type: none"> • Controller for up to 6 thermostats and 8 actuators 	<ul style="list-style-type: none"> • Expandable to 12 thermostats and 14 actuators with slave module 	<ul style="list-style-type: none"> • Expandable to 12 thermostats and 14 actuators with slave module 	<ul style="list-style-type: none"> • Configurable for heating and/or cooling 	<ul style="list-style-type: none"> • Controls up to 8 zones and 16 thermal actuators
<ul style="list-style-type: none"> • Expandable to 12 thermostats and 14 actuators with slave module 	<ul style="list-style-type: none"> • Timer with Eco/Comfort modes 	<ul style="list-style-type: none"> • Timer with Eco/Comfort modes 	<ul style="list-style-type: none"> • 3 thermostat options: programmable (Space PLUS) or digital or dial (Space) 	<ul style="list-style-type: none"> • 2 Channel set back time control
<ul style="list-style-type: none"> • 5 thermostat designs 	<ul style="list-style-type: none"> • 4 thermostat designs 	<ul style="list-style-type: none"> • 4 thermostat designs 	<ul style="list-style-type: none"> • 2 relays with LEDs 	<ul style="list-style-type: none"> • 2 thermostat designs
<ul style="list-style-type: none"> • Digital thermostats with backlit display 	<ul style="list-style-type: none"> • Digital thermostats and timer with backlit display 	<ul style="list-style-type: none"> • Digital thermostats and timer with backlit display 	<ul style="list-style-type: none"> • Radio connection LED 	<ul style="list-style-type: none"> • Programmable or non programmable
<ul style="list-style-type: none"> • Floor and remote sensor options 	<ul style="list-style-type: none"> • Floor and remote sensor options 	<ul style="list-style-type: none"> • Floor and remote sensor options 	<ul style="list-style-type: none"> • Electronic control of 2-way valve 	<ul style="list-style-type: none"> • Thermostats can be connected to floor sensors
<ul style="list-style-type: none"> • Relative humidity sensor in selective thermostats 	<ul style="list-style-type: none"> • Relative humidity sensor in selective thermostats 	<ul style="list-style-type: none"> • Relative humidity sensor in selective thermostats 	<ul style="list-style-type: none"> • Floor and remote sensor options 	
<ul style="list-style-type: none"> • Heating and advanced cooling control 	<ul style="list-style-type: none"> • Heating and cooling control 	<ul style="list-style-type: none"> • Heating and cooling control 	<ul style="list-style-type: none"> • Can be used for radiator systems 	
<ul style="list-style-type: none"> • Pump and valve exercise 	<ul style="list-style-type: none"> • Pump and valve exercise 	<ul style="list-style-type: none"> • Pump and valve exercise 	<ul style="list-style-type: none"> • Ideal for controlling Push12 	
<ul style="list-style-type: none"> • No manual balancing 	<ul style="list-style-type: none"> • No manual balancing 	<ul style="list-style-type: none"> • No manual balancing 	<ul style="list-style-type: none"> • Integrates fully with other Smatrix controls 	
<ul style="list-style-type: none"> • Uponor's patented "Autobalance" technology independently tested and verified to save up to 20% in energy use 	<ul style="list-style-type: none"> • Uponor's patented "Autobalance" technology independently tested and verified to save up to 20% in energy use 	<ul style="list-style-type: none"> • Uponor's patented "Autobalance" technology independently tested and verified to save up to 20% in energy use 		
<ul style="list-style-type: none"> • Optional relay module for heating/cooling switchover 	<ul style="list-style-type: none"> • Optional relay module for heating/cooling switchover 	<ul style="list-style-type: none"> • Optional relay module for heating/cooling switchover 		
<ul style="list-style-type: none"> • Micro SD card for data logging, backup and software updates 				

Room Controls

With underfloor heating (UFH), the basic principles of domestic thermostatic control remain the same. The floor of a room can be considered to be a large low surface temperature radiator, but instead of a self-regulating thermostatic radiator valve to provide room temperature control, a room thermostat is used to open and close a loop(s) on the UFH manifold. Alternatively, a single room sensor or programmable room thermostat can be used to control the UFH as a single zone.

Uponor recommends that all UFH systems are equipped with room temperature controls, to optimize operating efficiency of the heating system and provide for the flexibility of independent control to each room or heating zone.

Wireless Control

Wireless Control is Uponor's preferred system for multi-zone installations. Wireless thermostats can be located almost anywhere within the room and easily relocated if necessary. No planning or cost for routing cables to thermostats simplifies the electrical installation. As well as standard wireless thermostats Uponor have developed a Premium version (Wave PLUS) with Touchscreen Interface and option for remote connection (U@home) via smartphone, tablet, laptop or smartTV. The Wireless Controller is a wiring centre with in-built relay logic that requires a 230 volt electrical supply and has an on board 230V/24V transformer for connection of 24V thermal actuators. Each room or zone is equipped with a room thermostat, which signals to open/close the thermal actuators fitted to the respective heating loops on the manifold. Up to 6 thermostats and 8 actuators (or 12 stats & 14 actuators with addition of slave module) can be connected to each wireless controller. While the Interface unit can manage up to 4 Controllers.

All controls are supplied with comprehensive installation and setup manuals, it is highly recommended these are thoughtfully read before commencing installation. For additional setup and installation assistance contact Uponor Technical Support.

Smatrix Wave



Smatrix Wave controller

A wireless radiant heating/cooling controller. The controller sends and receives radio signals to and from room thermostats and sensors to control thermal actuators and other heating/cooling equipment.

Description	Code	Qty
X-163 UK 6X	1071649	1 pce.



Smatrix Wave slave module

A 6 channel controller slave module M-140. The controller slave can be added to a Smatrix Wave Plus and Wave controller, to expand the available channels (6) and actuator outputs (6).

Description	Code	Qty
M-160 6X	1071659	1 pce.



Smatrix Wave timer

A wired timer device for eco/comfort time schedule communication to the Smatrix Wave controller, with large backlit display. It provides a user-friendly menu as well as pre-defined eco/comfort schedules and is freely programmable if required. Other features such as holiday mode are also available within the timer.

Description	Code	Qty
I-163	1086985	1 pce.



Smatrix Wave thermostat prog.

A wireless digital programmable thermostat with Rh sensor and large backlit display. It measures and displays the room temperature and Rh, then transmitting the values to the wireless controller.

Description	Code	Qty
+RH T-168	1086984	1 pce.

Smatrix Wave



Smatrix Wave thermostat standard

A wireless dial single room temperature sensor with printed scale on dial. It measures the perceived room temperature, transmitting the values to the wireless control unit.

Description	Code	Qty
Standard T-165 POD	1086981	1 pce.



Smatrix Wave thermostat public

A wireless single room temperature sensor for public buildings. In addition, different sensors functions such a floor sensor, remote sensor and outdoor sensor can be set via dip switch . It measures the perceived temperature and transmits the values to the wireless controller.

Description	Code	Qty
T-163	1086979	1 pce.



Smatrix Wave thermostat digital

A wireless digital thermostat with large backlit display. It measures and displays the room temperature, transmitting the values to the wireless controller.

Description	Code	Qty
T-166	1086982	1 pce.



Smatrix Wave relay module

A wireless dual output receiver which can be used to switch different devices on or off. In addition it can be used for a wireless H/C switch over between the Smatrix room control system and the supply water controller or heat source.

Description	Code	Qty
M-160 6X	1071658	1 pce.



Uponor Smatrix wallframe

The Smatrix wall frame for all Smatrix thermostats.

Description	Code	Qty
T-X A-1XX	1086986	1 pce.
T-X GREY A-1XX	1071665	1 pce.



Uponor Smatrix sensor floor/remote

The Smatrix floor/remote sensor can be combined with selected room thermostats out of the Smatrix Base, Smatrix Wave and Smatrix Wave Plus portfolio.

Description	Code	Qty
S-1XX	1071684	1 pce.

Smatrix Wave PLUS



Uponor Smatrix Wave Plus control set

A wireless radiant heating/cooling controller and interface set, with the option of remote connectivity via U@home. Upto an additional 3 Wave Plus controllers providing a 48 zones control platform. The controller sends and receives radio signals to and from room thermostats and sensors to control thermal actuators and other heating/cooling equipment. Settings and full system information via the radio touch screen.

Description	Code	Qty
X-165+I-167 UK 6X	1071647	set



Uponor Smatrix Wave Plus thermostat

A wireless single room temperature and Rh sensor and large backlit display. It measures and displays the room temperature and Rh, transmitting the values to the wireless controller.

Description	Code	Qty
D+RH T-167	1086983	1 pce.



Uponor Smatrix Wave Plus controller

A Wireless Radiant Heating/Cooling Controller. The Controller sends and receives radio signals to and from room thermostats and sensors to control thermal actuators and other heating/Cooling equipment. Can be added to a Smatrix Wave Plus Control Unit as a sub-controller to expand the system to up to 4 Controllers depending on specific installation size.

Description	Code	Qty
X-165 UK 6X	1071668	1 pce.



Smatrix Wave slave module

A 6 channel controller slave module M-140. The controller slave can be added to a Smatrix Wave Plus and Wave controller, to expand the available channels (6) and actuator outputs (6).

Description	Code	Qty
M-160 6X	1071659	1 pce.



Uponor Smatrix Wave Plus thermostat

A wireless single room temperature and Rh sensor and large backlit display. It measures and displays the room temperature and Rh, transmitting the values to the wireless controller.

Description	Code	Qty
D+RH T-167 GREY	1071674	1 pce.



Uponor Smatrix Wave Plus U@home module

The Uponor Smatrix Wave Plus U@home module R-167 is a device which will bring more value and comfort to the end user and installer. Acting as interface between the Uponor Smatrix Wave Plus interface I-167 and your PC, Smart TV or mobile devices (tablet/smart phone)

Description	Code	Qty
R-167 UK	1084691	1 pce.

Smatrx Wave PLUS



Smatrx Wave thermostat standard

A wireless dial single room temperature sensor with printed scale on dial. It measures the perceived room temperature, transmitting the values to the wireless control unit.

Description	Code	Qty
Standard T-165 POD	1086981	1 pce.



Smatrx Wave thermostat public

A wireless single room temperature sensor for public buildings. In addition, different sensors functions such a floor sensor, remote sensor and outdoor sensor can be set via dip switch . It measures the perceived temperature and transmits the values to the wireless controller.

Description	Code	Qty
T-163	1086979	1 pce.



Smatrx Wave thermostat digital

A wireless digital thermostat with large backlit display. It measures and displays the room temperature, transmitting the values to the wireless controller.

Description	Code	Qty
T-166	1086982	1 pce.



The Smatrix wall frame for all Smatrix thermostats.

Description	Code	Qty
T-X A-1XX	1071675	1 pce.
T-X GREY A-1XX	1071665	1 pce.



Uponor Smatrix sensor floor/remote

The Smatrix floor/remote sensor can be combined with selected room thermostats out of the Smatrix Base, Smatrix Wave and Smatrix Wave Plus portfolio.

Description	Code	Qty
S-1XX	1071684	1 pce.

Smatrix Space

Single zone thermostat and controller packs ideal for new build and renovation projects. Also suitable for radiator installations. Each pack includes a wireless receiver and a wireless thermostat for ease of installation and setup.



Smatrix Space renovation set

Pack incorporating a single dial thermostat for heating projects.

Description	Code	Qty
X-161+T-165 UK	1071680	1 set



Smatrix Space Plus renovation set

Pack incorporating a digital thermostat for heating projects.

Description	Code	Qty
X-161+T-166 UK	1071692	1 set



Smatrix Space cooling set

Pack incorporating a programmable digital RH thermostat suitable for both heating and/or cooling projects.

Description	Code	Qty
X-161+T-168 UK	1071672	1 set

Smatrix Base



Smatrix Base controller

A wired radiant heating/cooling controller. The controller sends and receives bus signals to and from room thermostats and sensors to control thermal actuators and other heating/cooling equipment.

Description	Code	Qty
X-145 BUS UK 6X	1071679	1 pce.



Smatrix Base slave module

A 6 channel controller slave module M-140. The controller slave can be added to a Smatrix Base controller, to expand the available channels (6) and actuator outputs (6).

Description	Code	Qty
M-140 BUS 6X	1071686	1 pce.



Smatrix Base star module

A remote connection module for upto 6 channels. It adds additional flexibility for remote wiring of thermostats from a central location. Utilising a common link back to the controller for ease and speed of installation.

Description	Code	Qty
M-141 BUS 12X	1071651	1 pce.

Smatrix Base



Smatrix Base thermostat standard

A wired dial single room temperature sensor with scale on dial. It measures the perceived room temperature and transmitting the values to the wired controller.

Description	Code	Qty
T-145 BUS POD	1086975	1 pce.



Smatrix Base thermostat public

A wired room thermostat for tamperproof locations. In addition, different sensors functions can be set via dip switch such a floor sensor, remote sensor and outdoor sensor.

Description	Code	Qty
T-143 BUS	1086972	1 pce.



Smatrix Base thermostat digital

A wired digital thermostat with large backlit display. It measures and displays the room temperature, transmitting the values to the wired controller.

Description	Code	Qty
T-146 BUS	1086976	1 pce.



Smatrix Base thermostat prog.

A wired digital programmable thermostat with Rh sensor and large backlit display. It measures and displays the room temperature and Rh, then transmitting the values to the Smatrix Base controller.

Description	Code	Qty
+RH T-148 BUS	1086977	1 pce.



Smatrix Base timer

A wired timer device for eco/comfort time schedule communication to the Smatrix Base controller, with large backlit display. It provides a user-friendly menu as well as pre-defined eco/comfort schedules and is freely programmable if required. Other features such as holiday mode are also available within the timer.

Description	Code	Qty
I-143 BUS	1086978	1 pce.



Smatrix Base bus cable

A 4 core Smatrix bus cable, individually shielded for interference protection.

Description	Code	Qty
A-145 10M	1071653	1 pce.
A-145 50M	1071670	1 pce.



Uponor Smatrix sensor floor/remote

The Smatrix floor/remote sensor can be combined with selected room thermostats out of the Smatrix Base, Smatrix Wave and Smatrix Wave Plus portfolio.

Description	Code	Qty
S-1XX	1071684	1 pce.

Base 230V

230V Wired Control

Uponor's 230 V hard wired control system, for multizone applications, provides mains voltage power to the thermostats and actuators. 2 room thermostat options available, digital programmable or dial type with digital temperature display. Both thermostats have the ability to regulate floor temperature through floor sensors. 4°C Night temperature setback is also available for the dial thermostat by using our single channel time clock, the 8 way control box can handle 2 setback time zones via remote time clock(s).



230V Wiring Centre

The 8 way controller is a relay/wiring centre that can control up to 16 x 230 V actuators via a maximum of 8 hard wired thermostats (230 V). The unit has two relays; one to send a demand signal to the heat source or water temperature control unit and one for a dedicated underfloor heating pump (if required).

Additional features of this unit include:

- Setback temperature with connection for up to 2 timers, or via BMS.
- Open system
- 2 volt free contacts for UFH pump and heat demand
- Lightweight unit
- Replaceable fuse
- 230 V wiring throughout

Description	Code	Qty
White 230V	1047456	1 pce.



230V Digital Programmable Thermostat

- Fully programmable 5/2 or 7 day with four heat levels per day
- Multiple regulation control choice: air only, air and floor or floor only
- Holiday mode with override feature
- Optimised start
- Lock facility/tamper proof setting
- 35mm pattress box required

Description	Code	Qty
White 230V	1058425	1 pce.



230V Digital Dial Thermostat

- 4°C night setback
- Multiple regulation control choice: air only, air and floor or floor only
- Lock facility/tamper proof setting
- Heat demand indicator

Description	Code	Qty
White 230V	1047457	1 pce.

Room Thermostat Mounting

Thermostats are generally mounted approximately 1.5m above floor level, away from draughts, direct sunlight or any other direct heating outlet which could affect the reading. If a room is likely, presently or sometime in the future, to be used by a wheelchair user then thermostat mounting height should be lowered to between 1 to 1.2 metres. An advantage of radio thermostats is that they can easily be repositioned within the room to suit any change in room use.

Thermal Actuators

Thermal actuators are fitted onto the UFH manifold and provide for automatic control of individual heating loops. They have an open and closed indicator window and take between 2–4 minutes to completely open.

Integration with Uponor Water Temperature Controls

The Uponor electronic control systems can easily be integrated with the Uponor range of water temperature control sets, including the 'V5 Compact Control Pack', 'VPG/PPG' and the 'Move X-157 Controller'. See electrical wiring details in Mechanical and Electrical Schematics chapter.

Single Zone Control

All water temperature controls supplied for a single zone application will be offered with either room or programmable thermostat. See electrical wiring details.

For full installation and user instructions refer to the manuals enclosed with each item (additional copies available on request).



More comfort for less energy

Smatrix with autobalancing

- Up to 20% energy saving compared to manually balanced systems
- Up to 25% faster reaction
- Fully automatic, 24/7
- Improved comfort
- Suitable for new build and renovation
- Retrofit optimises existing installations

For more information, please visit us at

www.uponor.co.uk

Electrical and Mechanical Schematics



The following section is designed to show the installer how their system is to be wired and plumbed. The electrical and mechanical schematics apply to both MLC and PEX systems.

ELECTRICAL SCHEMATICS

Smatrix Base	68
Smatrix Wave	70
Smatrix Wave PLUS	71
Smatrix Space	72
Smatrix Move	73
Base 230V	74

MECHANICAL SCHEMATICS

Compact Control Pack V5	75
VPG-10 Pump Group	76
PPG-20 Pump Group	77
3-port Motorised Valve	78
No Water Temperature Control	79
Typical Pipe Layout	80

Electrical Schematics

Smatrix Base - Wired

Uponor
Electrical Schematic
Smatrix Base (Wired)
 Ref: SB-1.0A

* Switch live demand is continued on the mechanical schematic or the Smatrix MOVE electrical schematic, if used.

Uponor reserve the right to alter specifications and operating parameters for all their systems at any time as part of their policy of continuous product development.

© Copyright Uponor Limited
 Copyright in this drawing belongs to Uponor Limited.
 This drawing may not be used, sold, licensed,
 transferred, copied or reproduced in whole or in part or
 in any manner or form other than with the prior written
 consent of Uponor Limited.

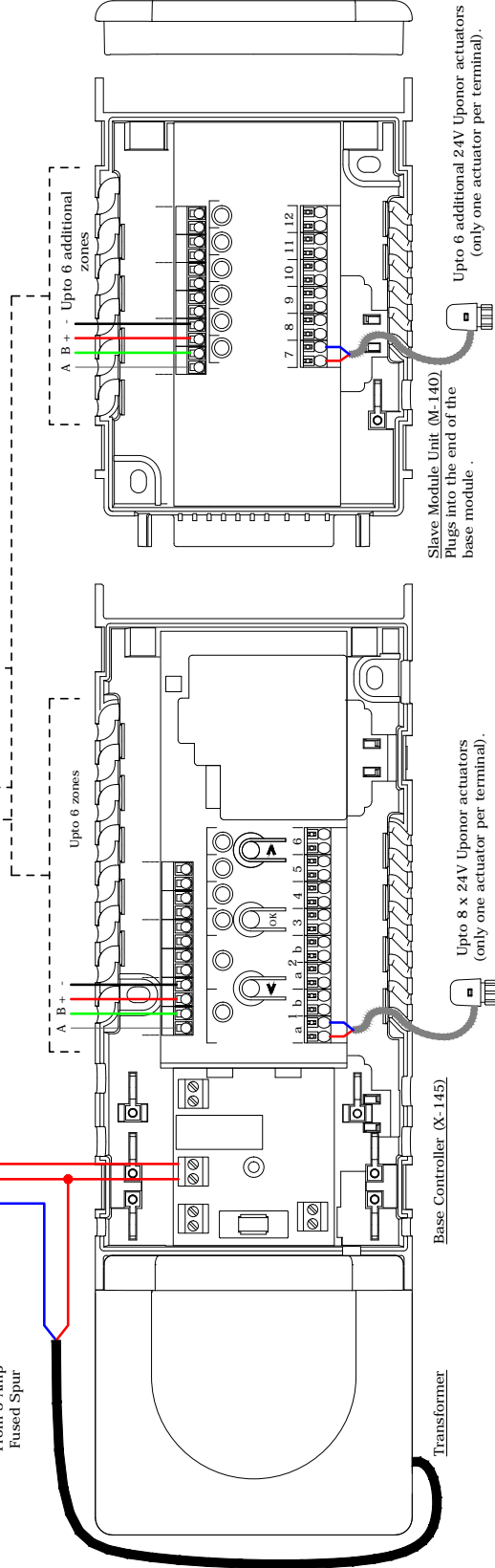
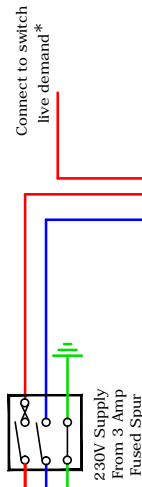
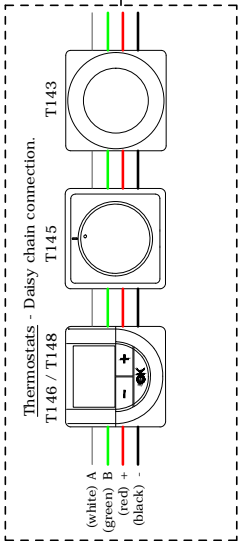
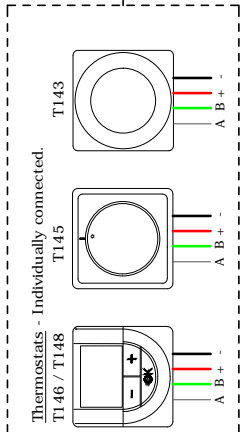
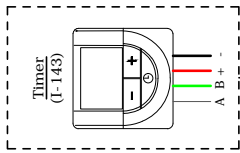
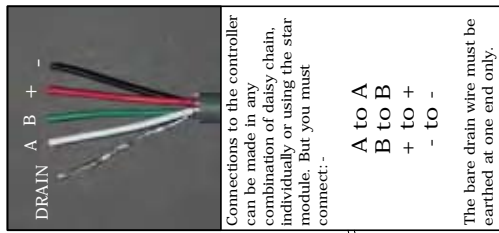

Upto 8 x 24V Uponor actuators
 (only one actuator per terminal).

Upto 6 additional 24V Uponor actuators
 (only one actuator per terminal).

Smatrix Base - Wired (Star module)

Uponor

Electrical Schematic
Smatrix Base Star Module (Wired)
Ref: SB-2.0A

Uponor reserve the right to alter specifications and operating parameters for all their systems at any time as part of their policy of continuous product development.

© Copyright Uponor Limited
Copyright in this drawing belongs to Uponor Limited.
This drawing may not be used, sold, licensed,
transferred, copied or reproduced in whole or in part or
in any manner or form other than with the prior written
consent of Uponor Limited.

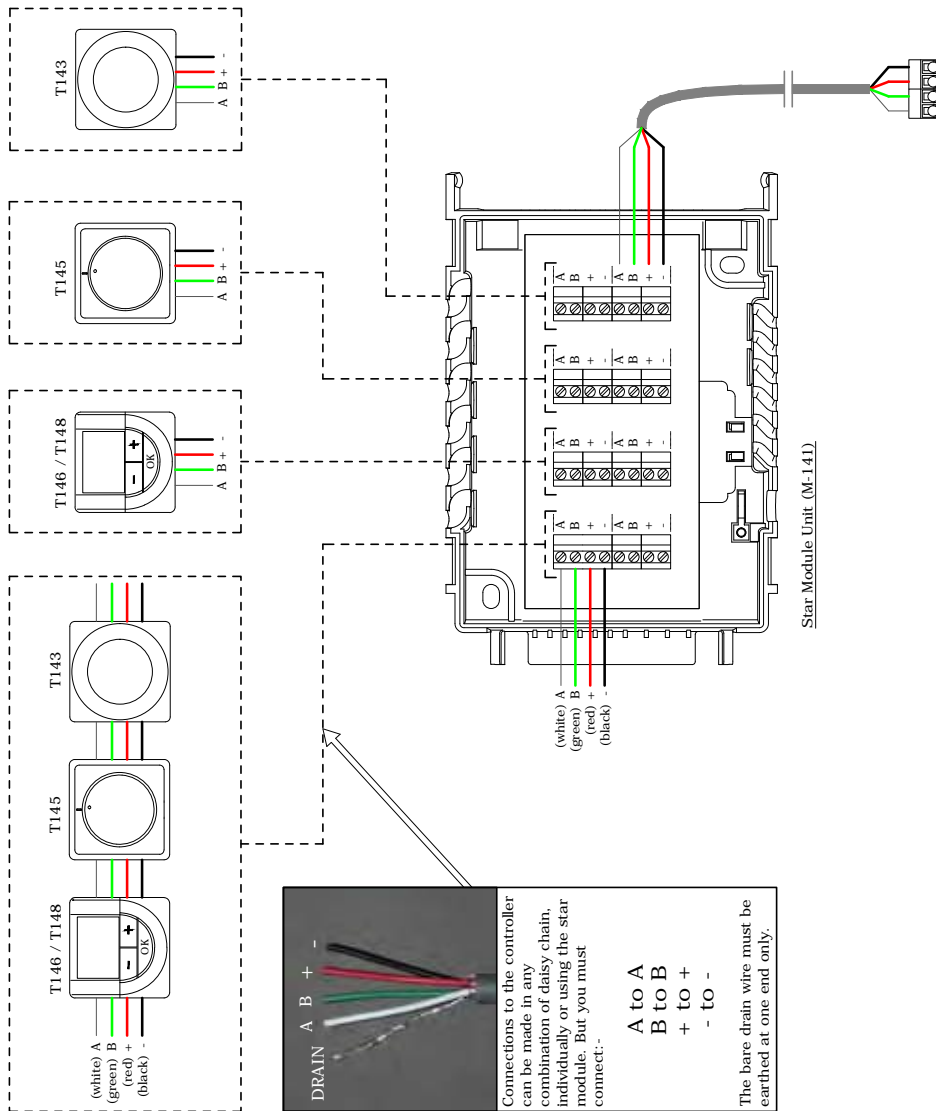

The Star Module must be either wired as shown into the Base Controller / Slave Module Unit or plugged into the end of them.

Smatrix Wave - Radio

Uponor
Electrical Schematic
 Smatrix Wave (Radio)
 Ref: SW-1.0A

* Switch live demand is continued on the mechanical schematic or the Smatrix MOVE electrical schematic, if used.

Uponor reserve the right to alter specifications and operating parameters for all their systems at any time as part of their policy of continuous product development.

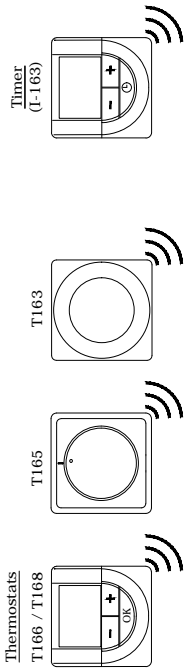

© Copyright Uponor Limited
 Copyright in this drawing belongs to Uponor Limited.
 This drawing may not be used, sold, licensed,
 transferred, copied or reproduced in whole or in part or
 in any manner or form other than with the prior written
 consent of Uponor Limited.

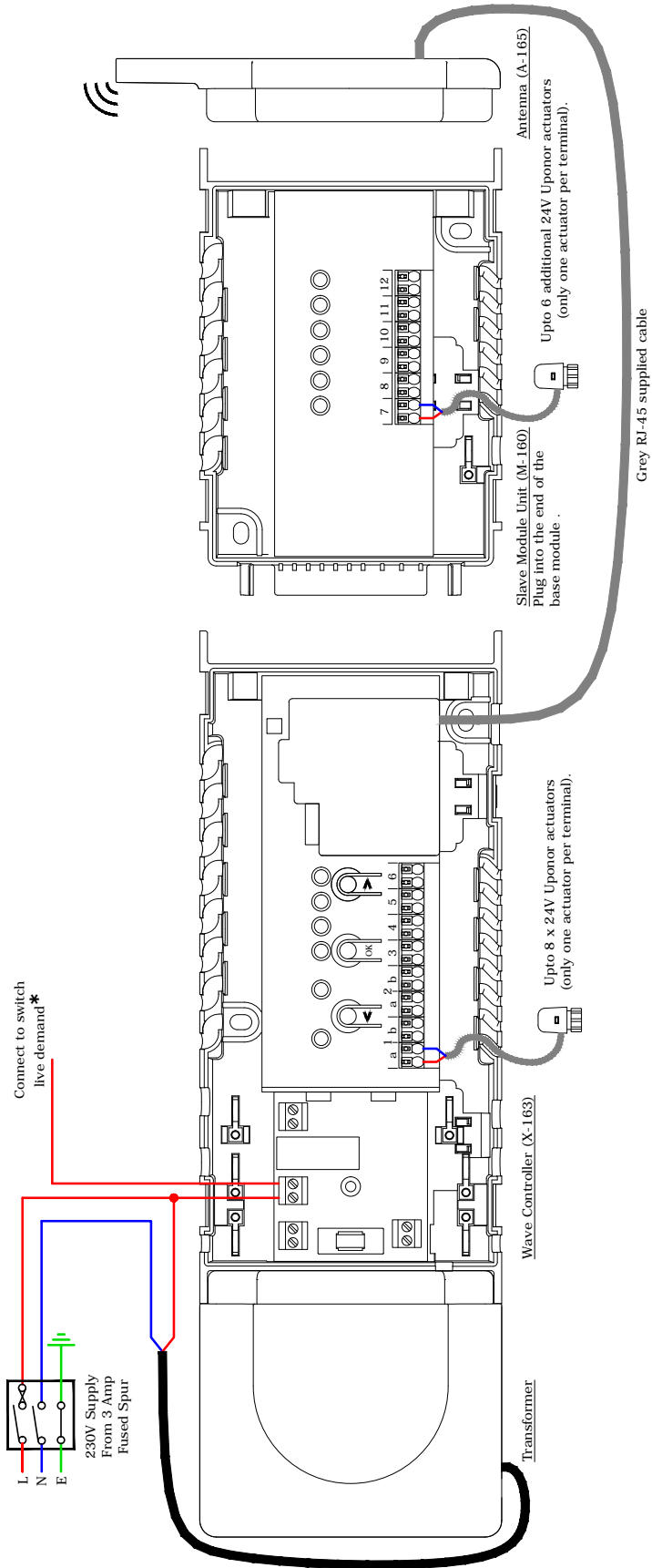

Smatrix Wave PLUS - Radio

Uponor
Electrical Schematic
 Smatrix Wave Plus (Radio)
 Ref: SW-2.0A

* Switch live demand is continued on the mechanical schematic or the Smatrix MOVE electrical schematic, if used.

Uponor reserve the right to alter specifications and operating parameters for all their systems at any time as part of their policy of continuous product development.

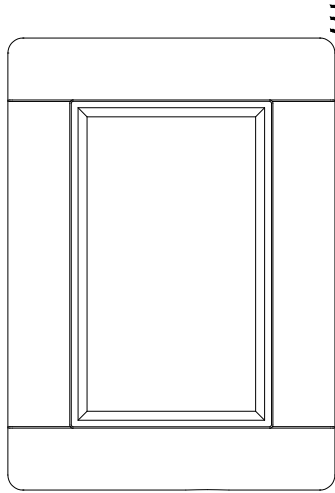
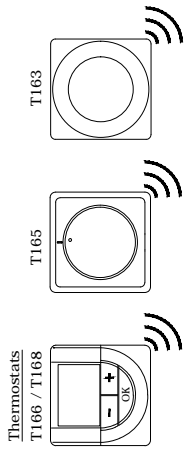

Optional Extra

Dry / volt free contact

Relay Module Unit (M-161)
 Optional relay for boiler control (Wave Plus only with interface)

© Copyright Uponor Limited
 Copyright in this drawing belongs to Uponor Limited. This drawing may not be used, sold, licensed, transferred, copied or reproduced in whole or in part or in any manner or form other than with the prior written consent of Uponor Limited.

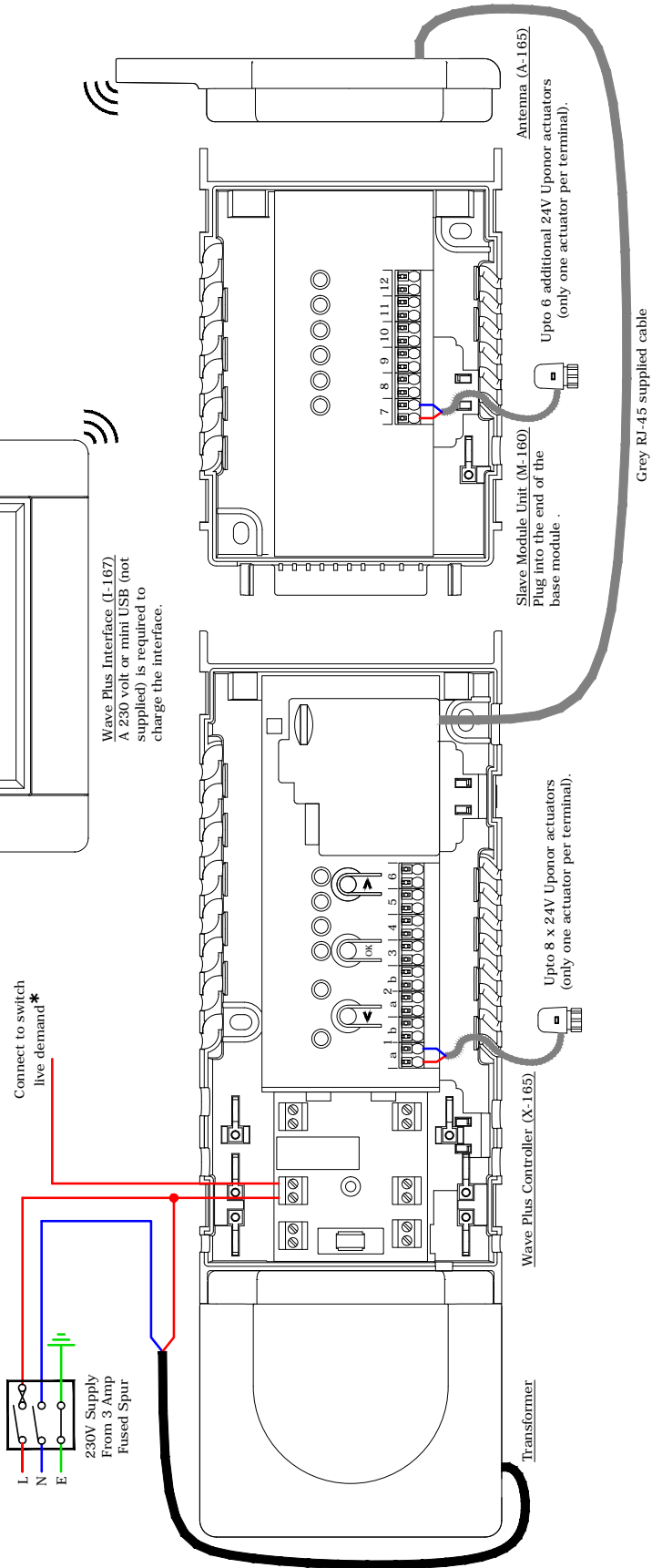

Smatrix Space - Radio

Uponor
Electrical Schematic
 Smatrix Space (Radio)
 Ref: SS- 1.0A

* Switch live demand is continued on the mechanical schematic or the Smatrix MOVE electrical schematic, if used.

Note:
 The Uponor 24V actuators, shown on the mechanical schematics, are not required for a single zone system.

Uponor reserve the right to alter specifications and operating parameters for all their systems at any time as part of their policy of continuous product development.

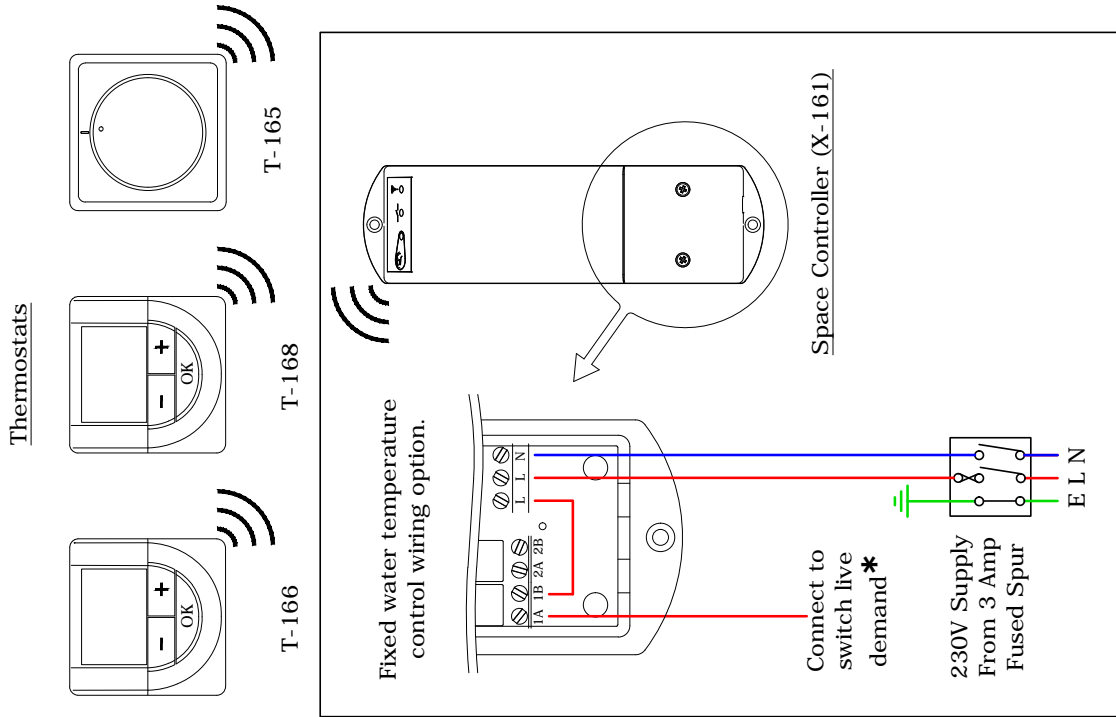

© Copyright Uponor Limited
 Copyright in this drawing belongs to Uponor Limited.
 This drawing may not be copied, reproduced, or
 transferred in any manner or form other than with the prior written
 consent of Uponor Limited.

Smatrix Move

Uponor
Electrical Schematic
 Smatrix Move
 Ref: SM-1.0A

Refer to the Quick Start Guide to setup pump and zone valve.

Uponor reserve the right to alter specifications and operating parameters for all their systems at any time as part of their policy of continuous product development.

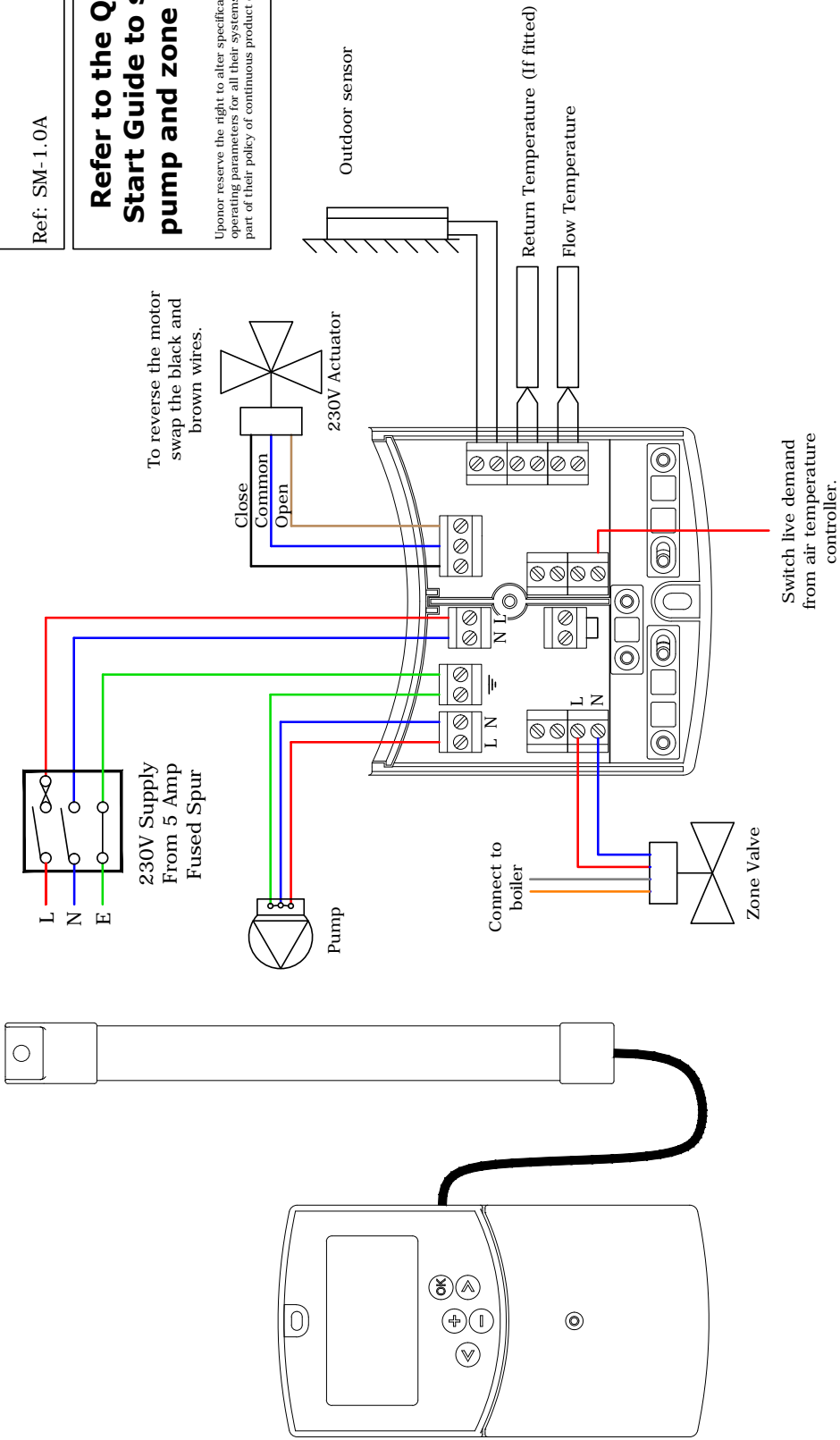

© Copyright Uponor Limited
 Copyright in this drawing belongs to Uponor Limited.
 This drawing may not be used, sold, licensed,
 transferred, copied or reproduced in whole or in part or
 in any manner or form other than with the prior written
 consent of Uponor Limited.

Base - 230V Wired

Uponor
Electrical Schematic
 Base (230V Wired)
 Ref: BAS-1.0A

* Switch live demand is continued on the mechanical schematic or the Ssmatrix MOVE electrical schematic, if used.

Uponor reserve the right to alter specifications and operating parameters for all their systems at any time as part of their policy of continuous product development.

230V Digital Dial Thermostat
 (Surface mounted)

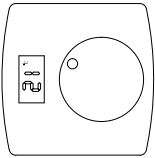

230V Digital Programmable Thermostat
 (Flush mounted)

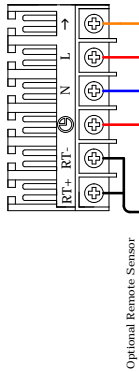
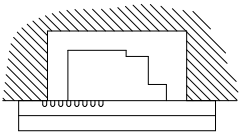

Optional Remote Sensor

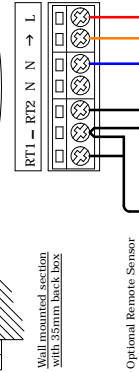

Optional Remote Sensor

Optional Remote Sensor

Wall mounted section with 35mm back box

Setback Time Switch
 Required to activate
 4°C setback on 230V
 Digital Dial Thermostat

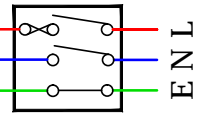
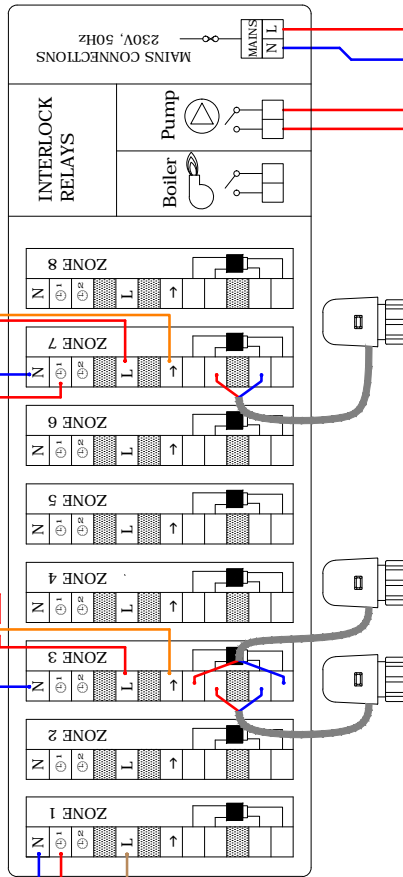
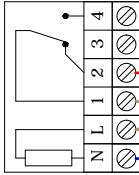

230V Supply
 From 3 Amp
 Fused Spur

Connect to switch live demand*

© Copyright Uponor Limited
 Copyright in this drawing belongs to Uponor Limited.
 This drawing may not be used, sold, licensed,
 transferred, copied or reproduced in whole or in part or
 in any manner or form other than with the prior written
 consent of Uponor Limited.

Mechanical Schematics

Compact Control Pack V5

Uponor

Mechanical Schematic
Compact Control Pack V5
Ref: CCP-1.0A

* Refer to air temperature electrical schematic for connection.

Manifold	Length
2 Port	340mm
3 Port	390mm
4 Port	440mm
5 Port	490mm
6 Port	540mm
7 Port	590mm
8 Port	640mm
9 Port	690mm
10 Port	740mm
11 Port	790mm
12 Port	840mm

The height of the compact control pack with manifold is 350mm and 135mm deep. The manifold needs to be mounted at least 300mm from the floor.

Notes:

- 1) A bypass is recommended on the primary circuit.
- 2) The drawing excludes isolating & regulating valves for clarity.
- 3) All items to be installed in accordance with manufacturer's instructions and current best practices.

Uponor reserve the right to alter specifications and operating parameters for all their systems at any time as part of their policy of continuous product development.

© Copyright Uponor Limited
Copyright in this drawing belongs to Uponor Limited.
This drawing may not be used, sold, licensed,
transferred, copied or reproduced in whole or in part or
in any manner or form other than with the prior written
consent of Uponor Limited.

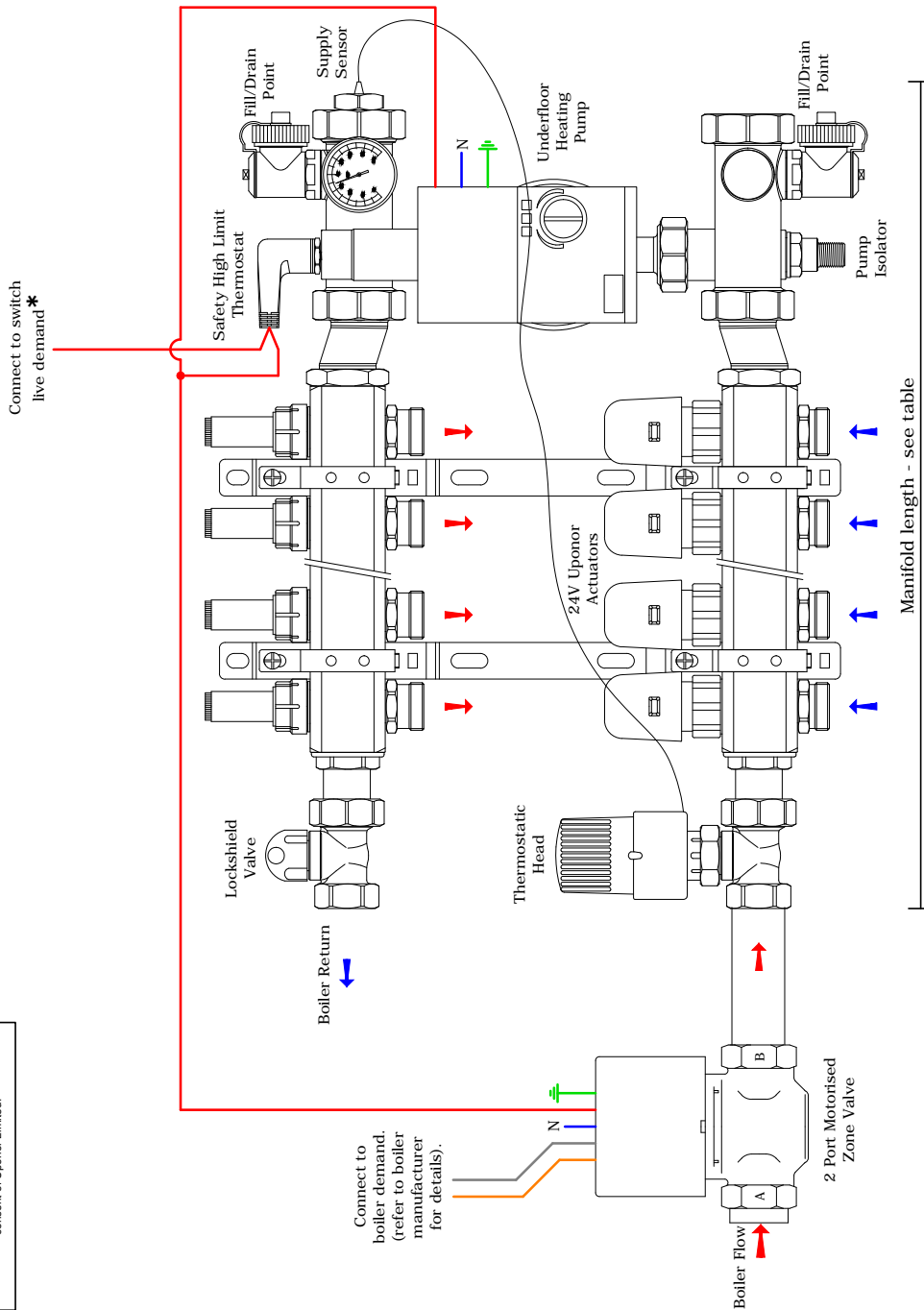

VPG-10 Pump Group

Uponor
Mechanical Schematic
 VPG 10
 Ref: VPG-1.0A

* Refer to air temperature electrical schematic for connection.

Manifold	Length
2 Port	147mm
3 Port	197mm
4 Port	247mm
5 Port	297mm
6 Port	347mm
7 Port	397mm
8 Port	447mm
9 Port	497mm
10 Port	547mm
11 Port	597mm
12 Port	647mm

The height of the manifold is 340mm and needs to be mounted at least 300mm from the floor.

Notes:
 1) A bypass is recommended on the primary circuit.
 2) The drawing excludes Isolating & regulating valves for clarity.
 3) All items to be installed in accordance with manufacturer's instructions and current best practices.
 4) If limited space is available the manifold and pump set may be split and installed in different locations to save space.

Uponor reserve the right to alter specifications and operating parameters for all their systems at any time as part of their policy of continuous product development.

© Copyright Uponor Limited
 Copyright in this drawing belongs to Uponor Limited.
 This drawing may not be used, sold, licensed,
 transferred, copied or reproduced in whole or in part or
 in any manner or form other than with the prior written
 consent of Uponor Limited.

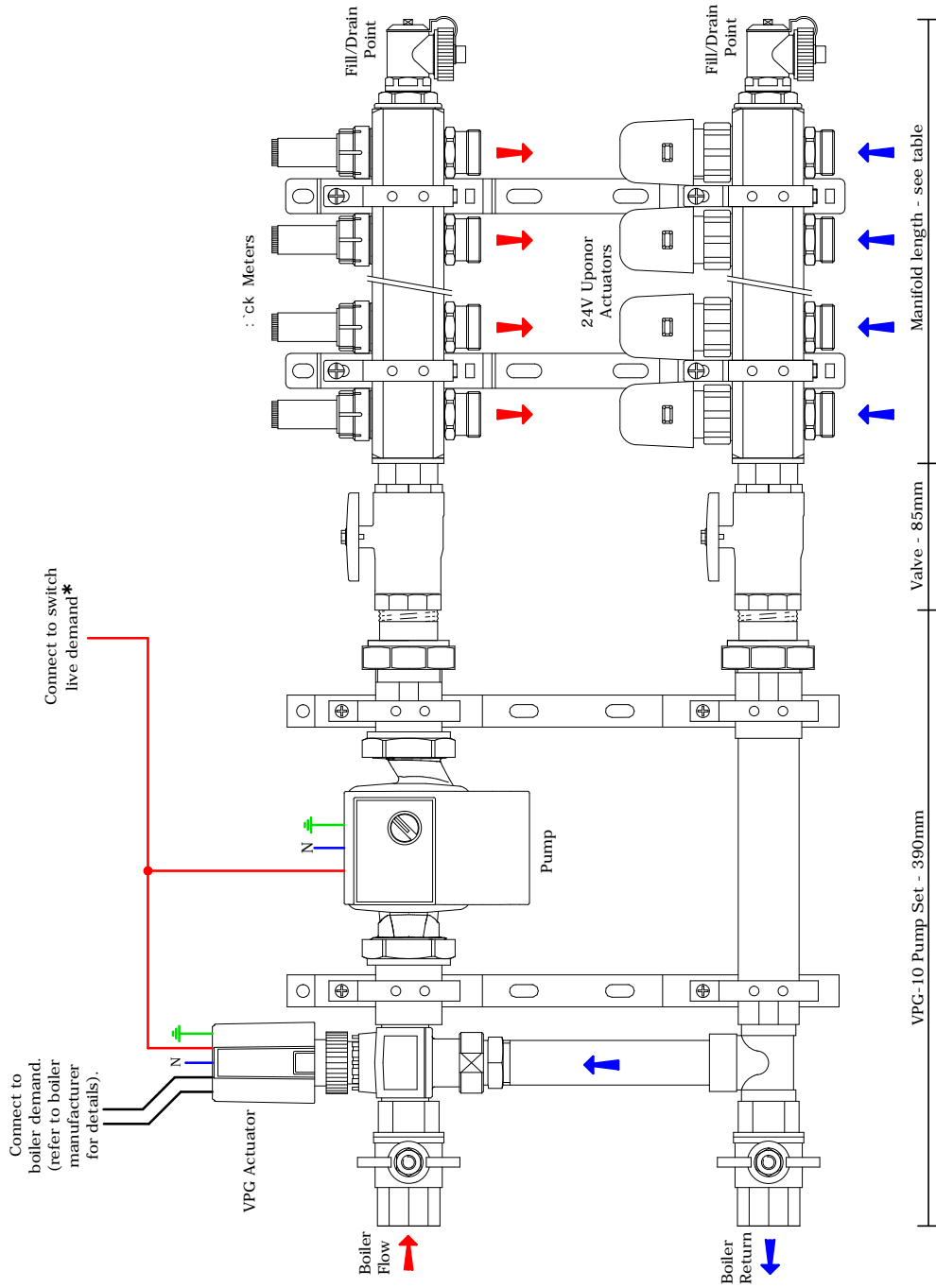

PPG-20 Pump Group



Mechanical Schematic PPG Pump Set Ref: PPG-1.0A

* Refer to Smatrix Move electrical schematic for connections.

Manifold	Length
2 Port	147mm
3 Port	197mm
4 Port	247mm
5 Port	297mm
6 Port	347mm
7 Port	397mm
8 Port	447mm
9 Port	497mm
10 Port	547mm
11 Port	597mm
12 Port	647mm

The height of the manifold is 340mm and needs to be mounted at least 300mm from the floor.

Notes:

- 1) A bypass is recommended on the primary circuit.
- 2) The drawing excludes Isolating & regulating valves for clarity.
- 3) All items to be installed in accordance with manufacturer's instructions and current best practices.
- 4) If limited space is available the manifold and pump set may be split and installed in different locations to save space.

Uponor reserve the right to alter specifications and operating parameters for all their systems at any time as part of their policy of continuous product development.

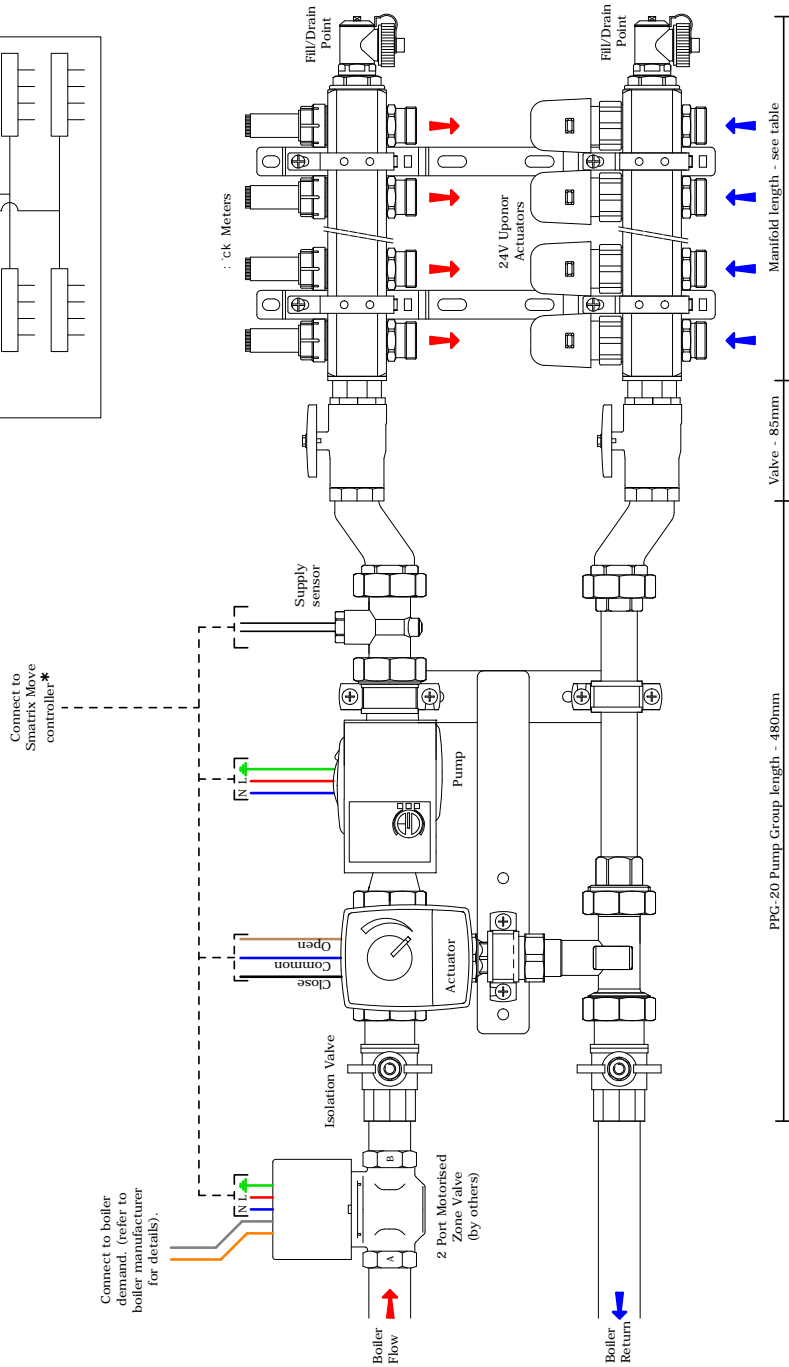
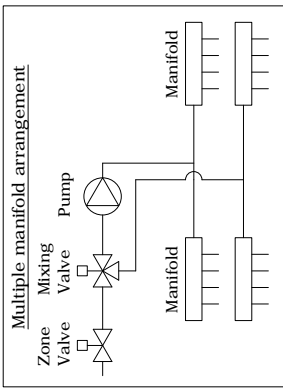

© Copyright Uponor Limited
Copyright in this drawing belongs to Uponor Limited. This drawing may not be used, sold, licensed, transferred, copied or reproduced in whole or in part or in any manner or form other than with the prior written consent of Uponor Limited.

3-port Motorised Valve

Uponor
Mechanical Schematic
 3 Port Mixing Valve
 Ref: 3PV-1.0A

* Refer to Smatrix Move electrical schematic for connections.

Manifold	Length
2 Port	147mm
3 Port	197mm
4 Port	247mm
5 Port	297mm
6 Port	347mm
7 Port	397mm
8 Port	447mm
9 Port	497mm
10 Port	547mm
11 Port	597mm
12 Port	647mm

The height of the manifold is 340mm and needs to be mounted at least 300mm from the floor.

Notes:
 1) A bypass is recommended on the primary circuit.
 2) The drawing excludes isolating & regulating valves for clarity.
 3) All items to be installed in accordance with manufacturer's instructions and current best practices.

Uponor reserve the right to alter specifications and operating parameters for all their systems at any time as part of their policy of continuous product development.

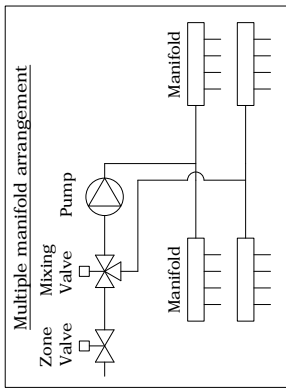

© Copyright Uponor Limited
 Copyright in this drawing belongs to Uponor Limited. This drawing may not be used, sold, licensed, transferred, copied or reproduced in whole or in part or in any manner or form other than with the prior written consent of Uponor Limited.

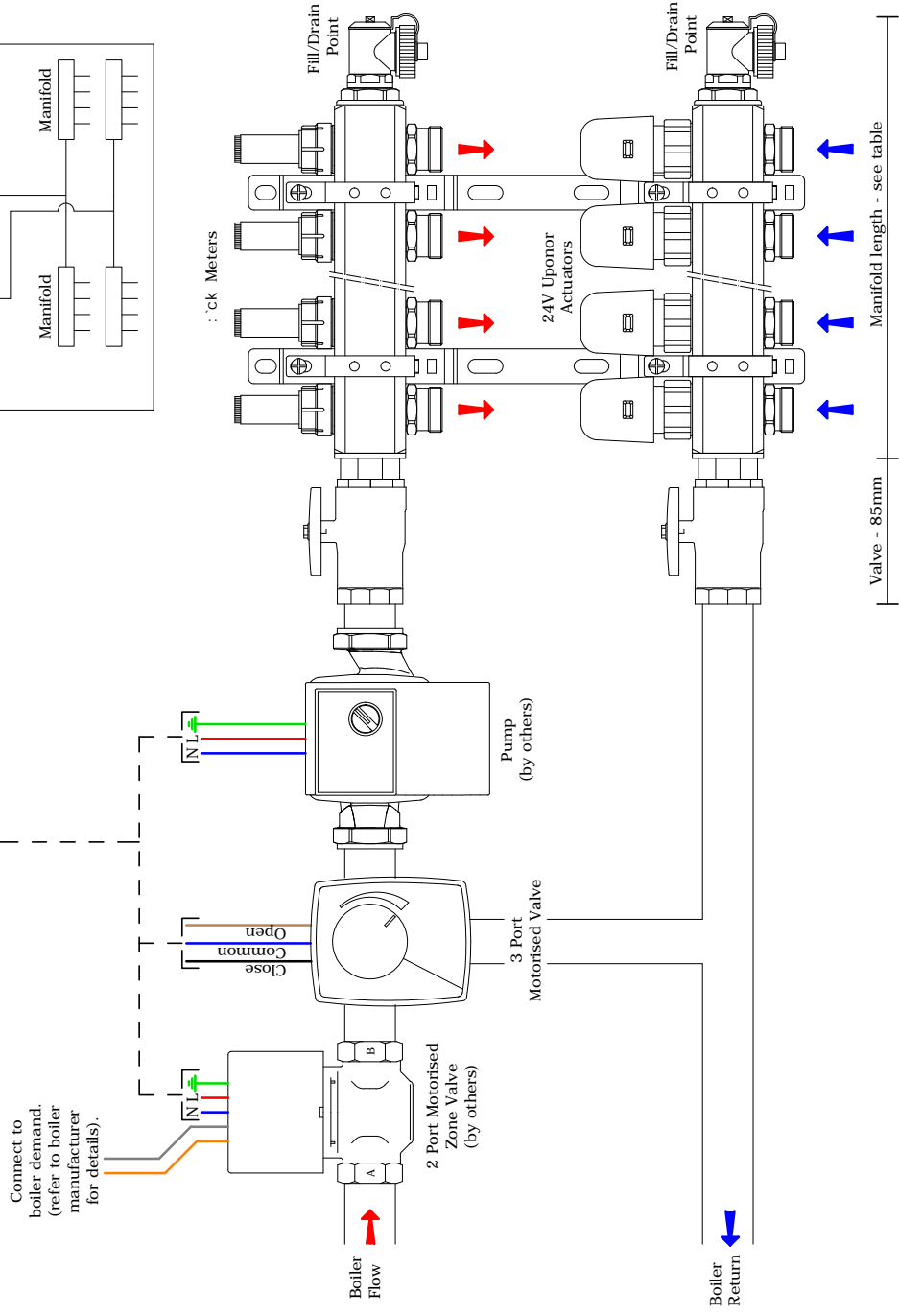

No Water Temperature Control

Uponor

Mechanical Schematic
No Water Temperature Control
Ref: NWT-1.0A

* Refer to air temperature electrical schematic for connection.

Manifold	Length
2 Port	147mm
3 Port	197mm
4 Port	247mm
5 Port	297mm
6 Port	347mm
7 Port	397mm
8 Port	447mm
9 Port	497mm
10 Port	547mm
11 Port	597mm
12 Port	647mm

The height of the manifold is 340mm and needs to be mounted at least 300mm from the floor.

Notes,

- 1) A bypass is recommended on the primary circuit.
- 2) The drawing excludes isolating & regulating valves for clarity.
- 3) All items to be installed in accordance with manufacturer's instructions and current best practices.

Uponor reserve the right to alter specifications and operating parameters for all their systems at any time as part of their policy of continuous product development.

© Copyright Uponor Limited
Copyright in this drawing belongs to Uponor Limited. It is hereby acknowledged that the whole or in part or transferred, copied or reproduced in whole or in part or in any manner or form other than with the prior written consent of Uponor Limited.

Connect to switch live demand*

Connect to boiler demand, (refer to boiler manufacturer for details).

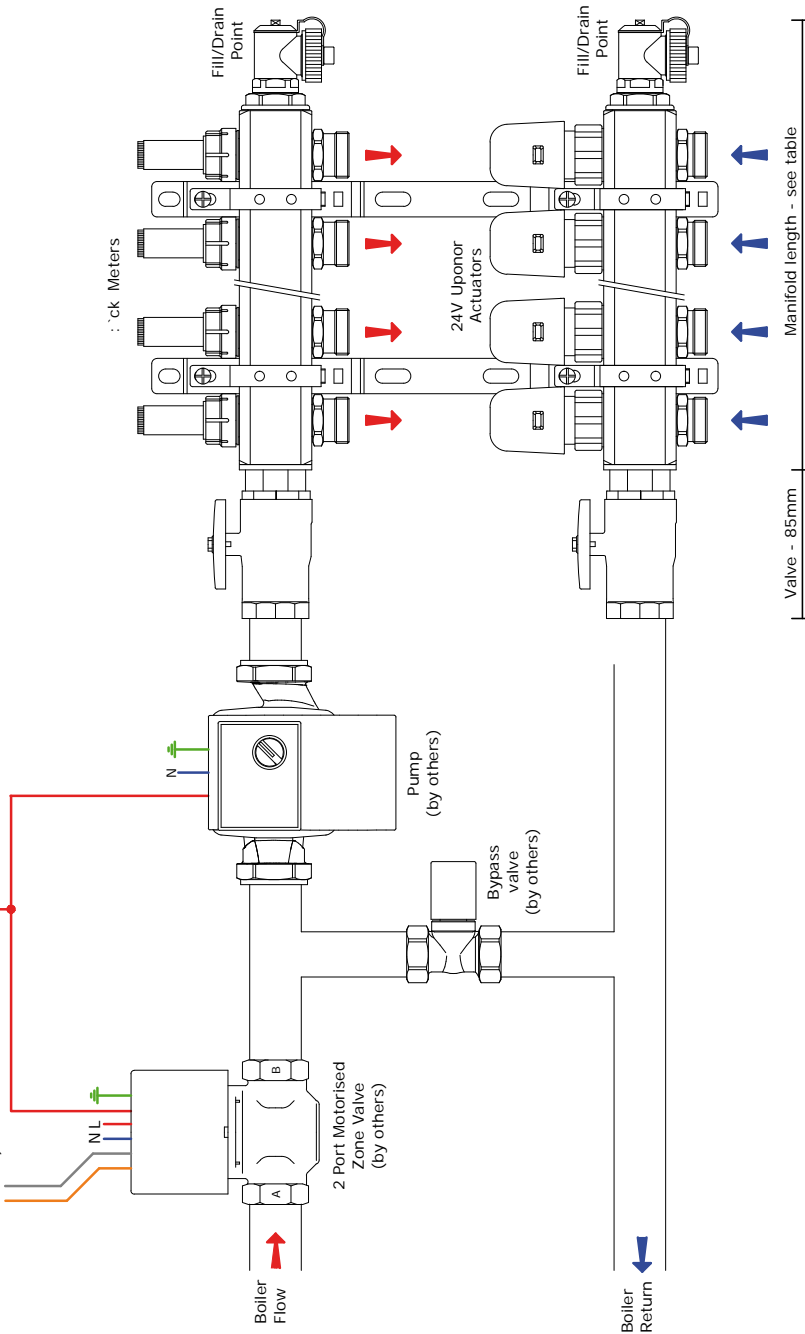

Example for Solid Ground Floor in a small domestic property

Drawing showing 4 zones for independent temperature control and with UFH manifold centrally located beneath the stairs.



Drawing showing room thermostat locations.



Drawing showing route of pipe tails from UFH manifold to each room.

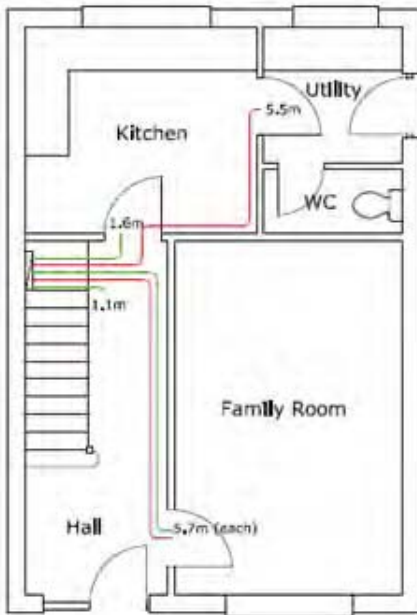

Drawing showing completed pipe layout.

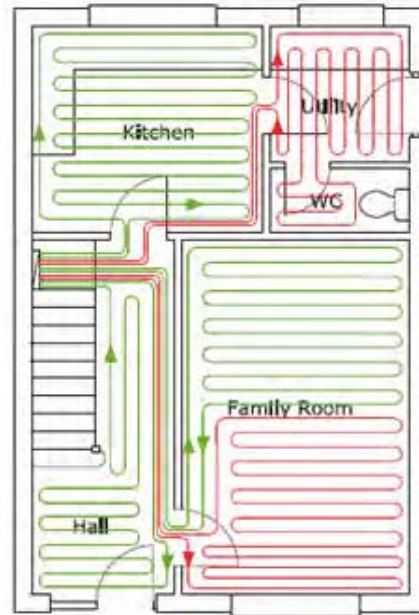

System details

Floor type:	Solid
Fixing Method:	Kombi Klips
Pipe size and type:	16mm MLC
Pipe pitch:	200mm
Max heat output:	100 W/m ²

Tabulated room details

Room or Zone (Number)	Room or Zone (Name)	Floor Area (m ²)	Distance to manifold (m)	No. of Loops (Qty)	Pipe Required (m)	Selected Coil Length
1	Kitchen	9.3	1.6	1	52.7	1 x 75m
2	Utility/WC	5.7	5.5	1	42.5	1 x 50m
3	Family Room	16	5.7	2	108.8	1 x 50m 1 x 75m
4	Hall	7	1.1	1	40.2	1 x 50m

* Please note that Uponor recommends laying UFH pipe underneath units.

Heat Pumps

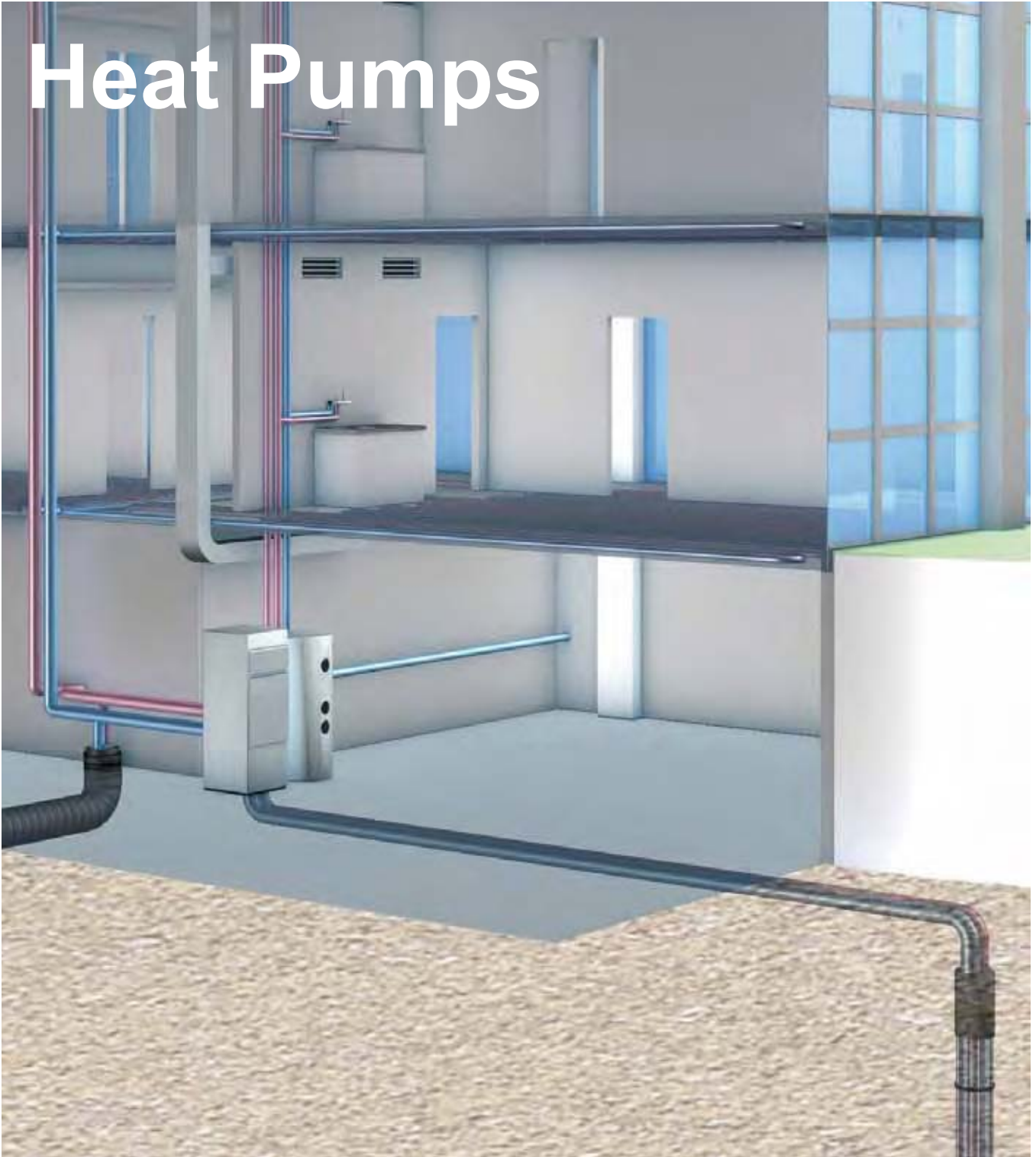

Uponor guidance on using heat pumps with an UFH system, and floor heat outputs for different UFH systems with various floor covering resistances.

Heat Pump

82

UFH Outputs with Floor Coverings

82

Heat Pumps

Uponor will not normally supply water temperature controls when ground/air source heat pumps are employed. The heat pump's integral controls should be set at a water temperature that satisfies the requirements of the UFH system. If you are using a heat pump and we have quoted the water temperature controls, please omit them from our offer or contact our technical team for advice.

To ensure for adequate water flow around the UFH loops additional circulating pump(s) will normally be required. Circulating pump(s) should be located at the inlet (upstream) of the manifold(s) and to be supplied by others. Uponor will be pleased to give advice regarding pump duty.

A buffer vessel is often fitted between the heat pump and the UFH manifold(s), which provides for adequate water circulation through the heat pump at all times when it is running. This also allows for individual room controls to be fitted to each underfloor heated zone, because the primary flow (Heat Pump circuit) is hydraulically separated from the secondary flow (UFH circuits). If a buffer vessel is not incorporated within your system, then sufficient UFH loops

should be uncontrolled (open circuit) to allow for adequate water flow rate through the heat pump to eliminate cycling.

Low mass UFH systems should only be used when heat requirements are so low as to allow operation well below the 50 – 55°C mean water temperature normally required. Such installations include plated systems for timber suspended and floating floors and void heating via the Unifoil system.

UFH with renewable energy heat generation should be designed to work on the lowest feasible water temperature to gain maximum energy saving benefits; heat pump coefficient of performance (COP) of 4 or more.

UFH will work with most types of floor coverings. However, it should be understood that coverings with relatively high thermal resistances will need to increase the UFH water temperature to offset building heat losses, and will result in lower COP and therefore higher running costs.

The tables that follow show floor heat outputs for different UFH systems with various floor covering resistances.

Typical Maximum Heat Outputs at 40°C Mean Water Temperature:

12mm PEX pipe (System 12)

Installation Type	Floor Heat Output (W/m ²)
Timber Panels at c/c 150mm and 0.1 m ² K/W combined resistance of floor deck and coverings	65
Floating Floor at c/c 125mm and 0.1 m ² K/W combined resistance of floor deck and coverings	60
Timber Panels at c/c 150mm and 0.15 m ² K/W combined resistance of floor deck and coverings	55
Floating Floor at c/c 125mm and 0.15 m ² K/W combined resistance of floor deck and coverings	50

16mm PEX or 16mm MLC pipe

Installation Type	Floor Heat Output (W/m ²)
Pipes embedded in screed at c/c 200mm. With low resistance floor covering, e.g. tiles	95
Pipes embedded in screed pipes at c/c 150mm and 0.1 m ² K/W floor covering thermal resistance	67
Pipes embedded in screed pipes at c/c 200mm and 0.1 m ² K/W floor covering thermal resistance	60
Plated system (timber or floating floors) at c/c 200mm with 18mm chipboard and 0.1 m ² K/W floor covering thermal resistance	40
Unifoil system (timber suspended floors) with 18mm chipboard and 0.1 m ² K/W floor covering thermal resistance	30
New Siccus FX floating (timber or floating floors) with 18mm chipboard and 0.1 m ² K/W floor covering thermal resistance	38

20mm PEX pipe

Installation Type	Floor Heat Output (W/m ²)
Solid floor at c/c 200mm. With low resistance floor covering, e.g. tiles	100
Solid floor at c/c 300mm. With low resistance floor covering, e.g. tiles	76
Solid floor at c/c 150mm and 0.1 m ² K/W floor covering thermal resistance	70
Solid floor at c/c 200mm and 0.1 m ² K/W floor covering thermal resistance	66
Solid floor at c/c 300mm and 0.1 m ² K/W floor covering thermal resistance	54
Plated system (timber or floating floors) at c/c 200mm with 18mm chipboard and 0.1 m ² K/W floor covering thermal resistance	46
Plated system (timber or floating floors) at c/c 300mm with 18mm chipboard and 0.1 m ² K/W floor covering thermal resistance	38

Tables based upon:

- 1) 20°C Room Temperature
- 2) For solid floors output is based on 45mm screed depth above the pipe
- 3) Sufficient insulation to prevent downward losses exceeding 10% of heat input

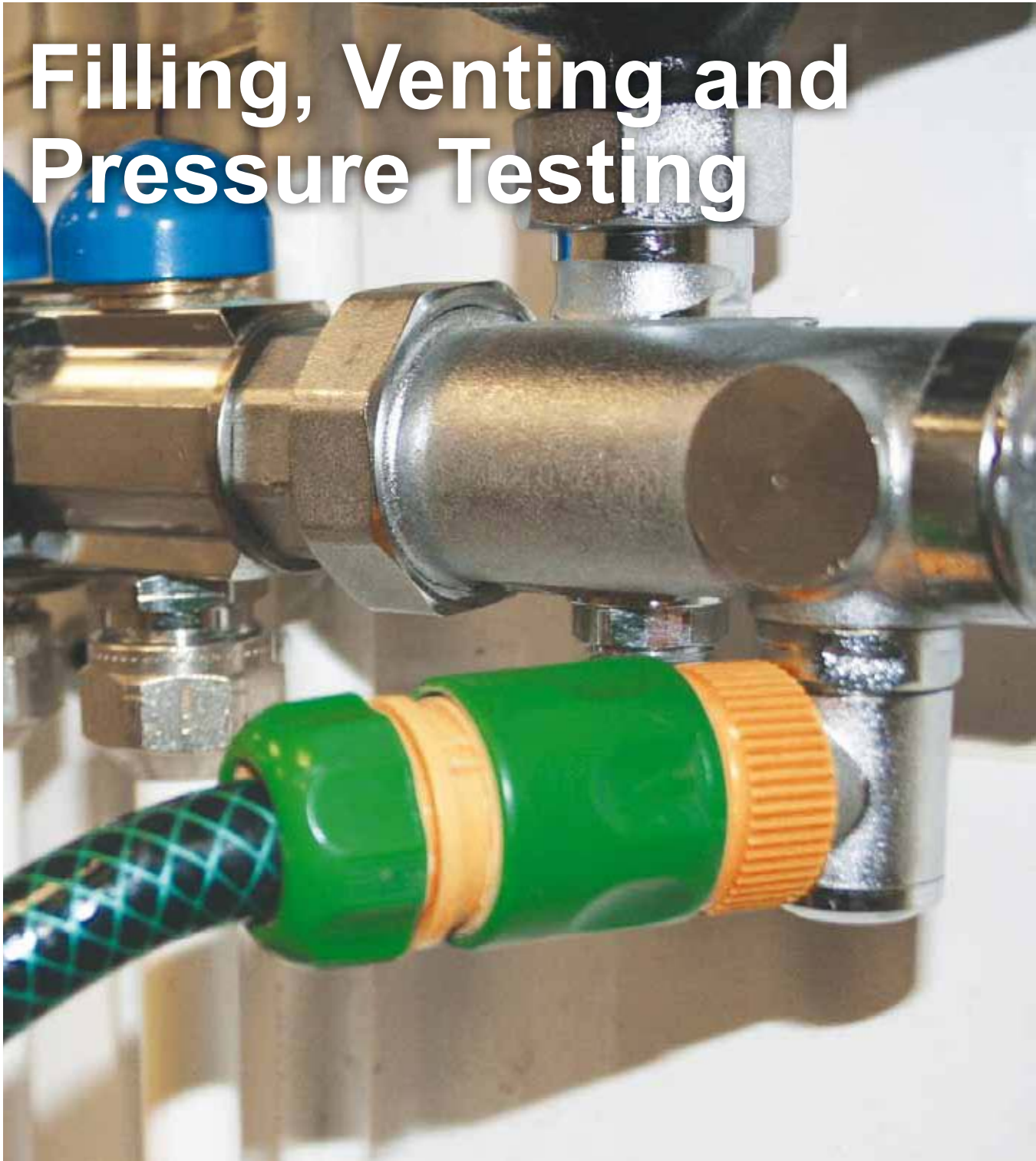

Filling, Venting and Pressure Testing

This section takes you through the required stages for filling, venting and pressure testing the system correctly.

Filling the loops

84

Pressure testing

85

Filling and Venting the Loops



There are integral fill/vent valves together with hose connections as part of the manifold assembly. Hose unions are required for the 3/4" thread on the Vario B manifold.



With Compact Control Pack V5 fitted to Vario B manifold the fill/vent valves would have been relocated to positions above and below the UFH pump.

Before starting, ensure that the fill port is uppermost, then:

- Ensure all electrical supplies are switched off.
 - Remove the fill port caps and washer and connect hose unions to both end caps.
 - The integral valves in both end caps must be opened to fill the system. Use the square key in the cap to open the fill port valves.
 - Ensure both isolating ball valves on the main flow and return pipes to the manifold are CLOSED. Alternatively, if a Compact Control Pack V5 is fitted close both control and lockshield valves. To close the control valve, firstly remove the thermostatic head and use one of the blue caps from a manifold loop to close the valve.
 - If using the V5 Compact Control Pack, fully close the valve on the elbow at the circulating pump inlet to ensure that water is forced around the UFH loops when filling and not short circuiting between the upper and lower manifold headers.
 - Close all underfloor heating loop flow and return valves on the manifold.
 - Fit a hose to the lower manifold hose union and run the other end of the hose to a suitable drain point.
 - Connect a hose to the upper manifold hose union and connect the other end of the hose to a mains water tap.
 - Individual loops need to be purged of air in turn. This is achieved by opening the manual head (blue cap) on the lower manifold, then fully opening the corresponding 1/2" meter on the upper manifold. To fully open the 1/2" meter, remove the red locking ring and turn the 1/2" meter 3 full turns from the closed position.
 - Turn on the water tap. As the first loop fills with water, air will discharge through the hose to the drain. Once the air stops and there is a steady flow of water, close both ports on the manifold.
 - Repeat this procedure for all UFH loops on the manifold ensuring that the valves are closed on each loop after filling.
 - Close the valves on the end caps and switch-off the mains water before disconnecting the hoses.
 - Important: If using a V5 Compact Control Pack, please remember to open the pimp isolation valve.
 - If the UFH is being installed in the winter, anti-freeze can be added to the system water for protection against freezing. If used, then the pipes will need to be fully flushed with cold water prior to running the system.
- The system is now ready for pressure testing.



Pressure Testing



Once the UFH pipes have been installed and filled, a hydraulic pressure test must be carried out on all loops prior to laying the screed or covering with the chosen floor coverings. A hydraulic pressure test kit is available from Uponor (Product Number 1004057).

- Isolate both the flow and return manifolds, using either the ball valves or control and lockshield valves if using the V5 Compact Control Pack.
- Ensure that all flow and return valves to the UFH loops are open.
- Use the pressure gauge on the pressure test kit to monitor pressures.
- Connect a pressure pump to the hose union and open the valve on this end cap. Ensure the other hose union valve is closed.
- Pump up the pressure in the manifold to 2 x the operating pressure (minimum 4 bar, maximum 6 bar) for at least 1 hour. After an initial slight drop in pressure as the pipes expand, there should be no further drop in pressure. Check the pressure gauge during this period to ensure that the pressure remains constant under this period.
- Decrease the pressure to the system working pressure, or a minimum of 2 bar. The system pressure will initially increase as the pipes contract under the lower pressures and will then stabilise. If the pressure has not fallen below working pressure after 1 hour the system is pressure tight.
- Uponor recommends that the system should remain under pressure whilst the floor is laid so that if any damage occurs to the pipe, the laying of the floor can be stopped and the damage repaired immediately. The floor should be laid immediately after the pressure test.
- Where there is a danger of freezing, suitable measures such as the use of glycol-based antifreeze should be taken, using the correct mixture of water and antifreeze solution. However, before start up, the glycol mixture should be thoroughly flushed out of the system and disposed of carefully.

Use of Corrosion Inhibitors

Uponor UFH pipes will not be:

- adversely affected by corrosion inhibitors normally used in central heating systems.
- adversely affected by accidental contact with linseed oil based sealing compounds, or soldering flux. However, the latter should not be used for making joints to the pipe.
- affected by soft, hard or aggressive potable water. The pipe will not be attacked by any constituents of concrete, screeds, mortars, and is fully resistant to attack from micro-organisms.

At the end of construction, the utilisation of a building begins

A vital phase that includes final approval of the construction work, and lays the foundations for efficient operation and maintenance.

At the commissioning stage, we support our partners in verifying the desired performance of our systems. Full and accurate final system documentation is always made available to the client. Our training enables building management professionals to ensure smooth and trouble-free operation. We offer support on our system's use, optimisation and eventual refurbishment – not just today and tomorrow but through the whole life cycle of a building.

Support Team

Uponor's professional support team can offer practical and technical advice to any query, providing remote and on-site customer support.

Direct Contact:

T 0844 8000 171

E support.uk@uponor.com





Starting-up the System Operation

This section helps you check and start-up the UFH system.

System Start-up - Vario B Manifolds	88	System Operation & Maintenance	91
Auto-Balance	90	Trouble Shooting	92

Starting-up the System

System Start-Up

When the system has been connected to the heat source and all pumps, controls, valves and bypasses fitted, the system should be checked and started as follows.

- Where applicable, ensure that the screed has had sufficient time to cure in accordance with manufacturers instructions and relevant British Standards, typically between 21 – 28 days.
- Check and ensure all electrical controls are wired correctly and in accordance with the latest edition of IEE Wiring Regulations, or ETCI National Rules for Republic of Ireland.
- The system set-up and control arrangement should be checked to ensure that it conforms to Uponor's recommendations.
- Check that the system is filled with water and fully vented of air and all isolating valves are fully open. Once this is complete, the pumps should be run for 5 minutes and a final check made to ensure that all air has been vented from the system.

- Check that the boiler or heat source is operating in accordance with the manufacturers instructions and set to run with a flow temperature of a minimum 15°C higher than the UFH design flow temperature. If the heat source is directly controlling the design flow water temperature, it should be set to the starting temperature of the system.
- The flow rate for each UFH loop (in litres/min) is regulated by Δ meters fitted to the flow header on flowmeter manifolds or lockshield balancing valves fitted to the flow header on valved manifolds. Set each loop by using the typical flow rate tables (overleaf) as a guide, and then carry out the balancing procedure that follows.

Important Note:

If Uponor Smatrix wired or wireless controls are used, then hydronic balancing will be carried out automatically by the control system, as long as "Autobalance" is enabled.

Flowmeter manifold loop balancing procedure:

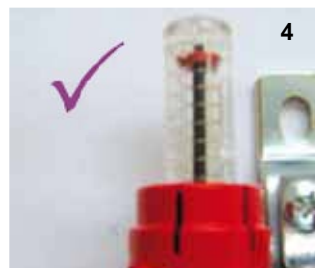
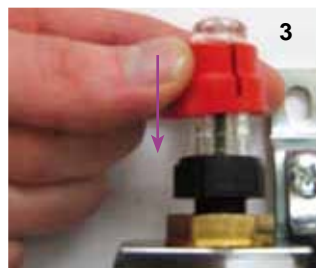
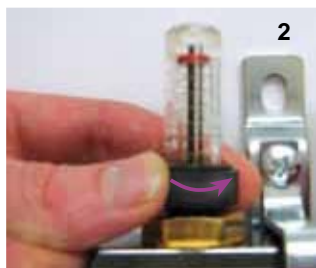
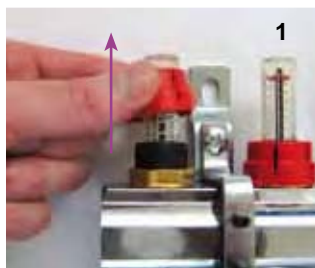

- Remove the red cover from the Δ meter as shown in Fig 1. If the Δ meter has been opened it needs to be closed by turning it clockwise. All Δ meters should be fully closed at the start of the commissioning process.
- Ensure that all manifold return valves are fully closed (remove thermal actuators if fitted and replace with blue manual caps).
- Open the return valve on one loop and adjust the setting of the corresponding Δ meter, until the design flow rate is

reached, by turning the Δ meter anticlockwise from its fully closed position as shown in Fig 2. It is important that the system and UFH pumps are running. Note, three full turns from shut will fully open the Δ meter. It is not possible to adjust the Δ meter further than this setting.

- Once the design flow rate is achieved the red locking ring should be refitted over the Δ meter as shown in Fig 3.
- The Δ meter will not turn at all if the red locking ring is fitted correctly. Fig 4 shows a correctly fitted locking ring.

Valved manifold loop balancing procedure:

- You will need the Technical Printout for your project together with a 5mm Allen Key to carry out the procedure. The Technical Printout shows the number of turns from closed for each lockshield valve.
- Ensure all lockshield valves are fully closed.
- Open each lockshield valve the required number of turns according to the Technical Printout. It is important to ensure that each valve is set to the correct value for the individual loop/area it serves.
- After the valve has been opened, replace and tighten the cap finger tight.

Important Note:

Manual loop balancing is not necessary if Uponor Smatrix controls are used and "Autobalance" is enabled.

Loop balancing for both Vario B manifolds (continued)

- Repeat the process for each loop, then go back and carry out fine adjustments, because each loop will have a mutual effect on the others. If the valve Δ , meter or lockshield is fully open and design flow rate is not achieved adjustment on the pump speed may be necessary.
- If removed, refit all thermal actuators.
- With the electric power off, initially set all room thermostats 5°C above current room temperature so that they call for heat.
- Set the water temperature control at the lowest possible setting (between 25 - 30°C).
- Switch on the UFH system and ensure UFH pumps are running and all relevant valves are open. Remember that the thermal actuators take some time to operate and there will be a 2 – 4 minute delay before they are fully open.
- If the foregoing procedures have been completed satisfactory, turn all room thermostats down and wait for the system to stop.
- When the system has stopped, turn up one room thermostat at a time and wait for the system to start. Then confirm that the correct circuit (loop) actuator(s) has opened for that particular room and immediately turn the room thermostat down again in that room.
- Wait until the system has stopped and then repeat the process on a room by room basis, ensuring that every actuator is controlled by the correct thermostat and that each one switched the system on and off. This should also include the boiler being switched on and off, providing there are no other user circuits, e.g. radiators and/or hot water primary circuits, calling for heat.
- Run the system at the lowest possible setting for at least 3 days, before raising the water temperature to the maximum design temperature, which should be maintained for at least a further 4 days.
- Set the room thermostats to the required levels and programme the system controls to run as required.
- When running normally, the temperature difference between the manifold flow and return connections may be between 5-10°C. To help assess the situation strap on thermometers are available. See the main price guide for details.

Final Loop Balancing

When the furnishings have been installed into the building and normal working conditions achieved, the loops may require a final balancing. The system should be run at design temperatures for at least one week before this is done.

General Commissioning

Commissioning is required to enable the system to meet its design specification and comply with the energy efficiency requirements of the Building Regulations. Commissioning should only be carried out after the system has been run gently for adequate time to allow floors to dry out (do not use the UFH to cure the screed). The building work should be complete with all external doors and windows closed. All safety checks relating to the boiler operation, controls wiring and water connections should have been performed in accordance with manufacturers instructions and with statutory requirements before system commissioning is commenced.

Floor heating systems are typically designed to operate with a water flow temperature of approximately 40 – 50°C and a return temperature of 5 – 10°C less. There are occasions, mainly concerning floor coverings, when resistance to heat flow is so great that the flow temperature must be increased to raise the floor surface temperature to achieve sufficient heat output.

Tables showing typical flow rates;

20mm PEX

Loop Length (m)	Floor Heat Output (W/m ²)		
	50	70	100
60	1.7 l/m	2.4 l/m	3.4 l/m
80	2.3 l/m	3.2 l/m	4.6 l/m
100	2.9 l/m	4.0 l/m	5.7 l/m
120	3.4 l/m	4.8 l/m	-

Note: Values based upon 20mm Uponor PEX pipes spaced at 300mm centres and with full coil usage, with a 7.5°C flow/return water temperature drop.

16mm PEX or 16mm MLC

Loop Length (m)	Floor Heat Output (W/m ²)		
	50	70	100
50	1.0 l/m	1.4 l/m	2.0 l/m
75	1.5 l/m	2.1 l/m	3.0 l/m
100	2.0 l/m	2.8 l/m	-
120	2.4 l/m	-	-

Note: Values based upon 16mm Uponor MLC or 16mm Uponor PEX pipes spaced at 200mm centres and with full coil usage, with a 7.5°C flow/return water temperature drop.

12mm PEX (Floating Floor System)

Loop Length (m)	Floor Heat Output (W/m ²)		
	50	70	100
40	0.5 l/m	0.7 l/m	1.0 l/m
60	0.8 l/m	1.1 l/m	1.5 l/m
80	1.0 l/m	1.4 l/m	-
100	1.3 l/m	N/A	-

Note: Values based upon 12mm PEX pipes spaced at 125mm centres and with a 7.5°C water temperature drop.

12mm PEX (Tigum Chipboard Panel System)

Loop Length (m)	Floor Heat Output (W/m ²)		
	50	70	100
40	0.6 l/m	0.9 l/m	1.2 l/m
60	0.9 l/m	1.3 l/m	1.8 l/m
80	1.2 l/m	1.7 l/m	-
100	1.5 l/m	N/A	-

Note: Values based upon 12mm PEX pipes spaced at 150mm centres and with an 7.5°C water temperature drop.

Autobalancing: continuously self-optimising temperature control

A unique technology that eliminates the need for manual balancing

Autobalancing constantly monitors changes in conditions inside and outside the building. By intelligently adjusting and adapting, Uponor Smatrix ensures that just the right amount of energy is used at just the right time.

With traditional controls, radiant heating and cooling needs balancing to fixed design conditions. This is a manual process that needs later adjustment to suit the actual building and occupiers preferences - a time consuming trial and error procedure. Autobalancing not only eliminates this initial commissioning adjustment - periodically the system optimises the circuit of each room, continuously calculating the energy

required for your comfort. Even if you change floor coverings, autobalancing will adapt automatically to ensure the right comfort levels with the most efficient energy use.

While the manual hydraulic balancing always considers only the initial conditions, the auto-tuning the temperature constantly adapts every change in to system or space, without complicated recalculation and adjustment by an installer. You save time, energy and money - you gain optimal comfort.

Autobalancing uses the exact amount of energy for optimal comfort

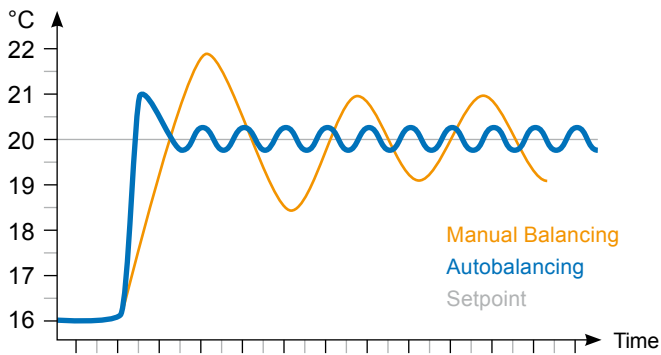

- Retrofit optimises existing installations
- Improved comfort without manual adjustments
- Fully automatic, 24/7
- Up to 25% faster reaction
- Energy saving:
 - Up to 6% compared to other single-zone controls
 - Up to 12% compared to unbalanced systems
 - Up to 20% compared to unbalanced multi-zone systems

Uponor Controls at a Glance

Features	Smatrix Wave PLUS	Smatrix Wave	Smatrix Base	Smatrix Space
Wireless	●	●		●
Wired			●	
Autobalancing	●	●	●	
Heating and cooling	●	●		
Humidity control	●	●		
Touchscreen interface	●			
Remote connectivity with U@home	●			
Comfort/Eco setting	●	●	●	●
Floor sensor	●	●	●	
Multi-zone	●	●	●	
Single-zone				●

System Operation

System Operation

Once the system has been correctly balanced and commissioned, there is very little to concern the client with operating Uponor Underfloor Heating.

Time Clocks

The UFH time clock is to be programmed to suit the building users requirements, depending upon their occupied and unoccupied periods during day and week; for example, when they go to work, or at what time they retire in the evening. It is normal for the UFH to be switched on approximately 2-3 hours before comfort conditions are required, especially true with screeded floors, due to the thermal lag associated with UFH. This also means the system can be switched-off approximately 2-3 hours before the end of the heating/occupied period.

The actual thermal lag is dependent upon the thermal mass of the floor structure; the thicker the screed the longer it will take to warm up and visa versa. Where the floor is of wooden structure, whose mass is typically one third of that of a screed floor, the response will be proportionately faster.

Air Thermostats

These can be adjusted to provide optimum comfort control. Once comfort conditions have been met, further adjustment of the thermostat should not be necessary. When a room thermostat setting is altered to call for more heat, providing the new setting is within the systems capabilities, it may take a while before a higher temperature is felt in the room. The rate of heat build up under most conditions will be fairly constant. Turning the thermostat up to higher temperature levels than it is desired to achieve cannot increase this rate.

ECO mode

Eco mode is ideal for UFH because it reduces warm-up times between unoccupied and occupied heating periods throughout the day/week by lowering the desired room temperature by approximately 4°C during unoccupied periods. This ensures that the system response at the next occupied period is faster, because to heat the screed from cold each morning would be impractical (not applicable with wooden or lightweight flooring systems). However, a well insulated screed floor may only lose 1.5 – 2°C over an 8 hour period, therefore when switched to unoccupied set-back, the UFH system will effectively be off except in cold weather.

Water Temperature Controls

The design water temperature should be set when the system is first commissioned and further adjustment is

not usually necessary, except when the system is under performing (see Trouble Shooting section). Adjustment is either directly on the water temperature control valves or on the Climate Controller. See specific installation instructions for further details.

Pump Speed

Increasing the pump speed will increase the flow rate and slightly improve the system response time.

Maintenance

Since the heating loops are embedded and the pipe does not corrode, no maintenance is necessary for the pipes. When the UFH system is not in use, e.g. during the summer months, the system should be run for 2 – 3 minutes each week to exercise the pumps and valves (the Climate Controller has a built-in pump and valve exercise programme). Pumps, valves and controls will require servicing as per the manufacturers instructions.

As for any plumbing joints, all joints at the manifold and flow and return should be checked regularly for any signs of leakage.

In older systems it is advisable to flush the system through with clean water to remove any sediment build-up.

Trouble Shooting

As described in earlier sections, the UFH system operation is relatively straightforward. Hot water from the primary heat source (boiler) is blended with the return water from the UFH secondary circuit at the mixing valve and distributed, via the secondary UFH pump, to the distribution manifold and into a series of UFH loops/circuits of pipe embedded within the floor. Normally, there is room temperature control, which will open and close a single or series of actuators mounted on the manifold, or prior to the manifold (single zone), depending upon the room requirement. If one or all thermostats are calling for heat, there is a boiler interlock switch to energise the boiler.

The majority of problems are usually simple installation problems, relating to wiring or plumbing, or design problems, with regard to the limitations of UFH and its suitability for the purpose intended.

In all cases where an electrical fault is reported it is always prudent to check the obvious before replacing components.

- Is there an electrical supply?
- Is it switched on?
- Are there any fuses that may have blown and need replacing?
- Are any components overloaded?
- Is everything wired correctly?

Under no circumstances replace a fuse with a higher rating than stated for that piece of equipment.

If the water arriving at the manifold (prior to entering the mixing valve) is either cold or below the design temperature, check:

- the boiler is firing
- the primary pump is fitted
- the primary pump is working
- the boiler is of adequate size
- the primary pipework is sufficiently sized
- the primary pumps are large enough

Further UFH Problems:

If a loop or loops fail to warm, when other zones are working correctly.

General things to look for:

- Check that the corresponding manifold valves are open
 - Check that there is a demand from the corresponding room thermostat and/or the thermal actuator is open on demand.
 - There may be an air lock in the loop, which will require purging. Either shut down all other loops by closing the valves at the manifold or turn down all other room thermostats. This will concentrate all pump pressure to the problem loop and may shift the air blockage. If all else fails the loop can be flushed through with high-pressure water following the instructions detailed in Filling, Venting and Pressure Testing.
- If circulation is apparent but poor, it may be that the regulating control valve on the manifold requires adjustment.
- Check that all pump isolating valves are fully open.

If a room fails to warm.

General things to look for:

- That the room thermostat fitted is calling for heat and that the valve has opened using the visual window on the actuator.
- That the room thermostat is connected to and communicating to the correct actuator(s).
- That the room thermostats are not operating in temperature set-back mode.
- That the flow temperature is correct as it enters the floor loops. Although typical design water temperatures are suggested throughout this guide, there is some element of a learning curve with UFH, as on some occasions the design water temperature may need to be raised after commissioning and once the system has been in operation during a heating season.
- That the primary flow and return connections are installed correctly and not crossed over at the UFH manifold.
- That the primary water temperature is not too low. This needs to be at least 15°C higher than the UFH system water temperature, especially when using a V5 Compact Control Pack.
- That the high limit thermostat on the V5 Compact Control Pack is not set too low.
- That the lockshield valve on the V5 Compact Control Pack is set correctly
- Thermal resistance of floor covering is not too high, as this could reduce the floor heat output.

If the system is too noisy.

General things to look for:

- There is no air in the system
- That all pipes are firmly clipped in place and that the manifold brackets are tight.
- That the UFH pump speed is not too high.
- That excessive pressure from another circulator in the system is not interfering (hence the importance of having a primary bypass).

If the running costs are high.

General things to look for:

- That the UFH system is correctly electrically connected to the boiler to prevent short cycling and to ensure that the boiler is not running when it is not required.
- That the room temperatures and thermostat settings are not too high (typical comfort temperatures are 20°C in living quarters and 18°C in bedrooms).
- For any open windows or draughts. It is not unknown for windows to be opened in cold weather, as the internal comfort remains constant with thermostatic controls.
- That the boiler is running correctly. Has it been serviced and/or commissioned by an approved engineer.
- That the floor downward losses are high due to inadequate level of floor insulation.

The design water temperature is not met

General things to look for:

- Check all control valves are correctly installed in their correct orientation and that any remote sensors are installed and located in a suitable position.
- Check the temperature settings are as per design and adjust as necessary, depending on the water temperature control system used.
- Check the primary water temperature is not too low. This needs to be at least 15 degrees in excess of the UFH system water temperature.

The system is losing pressure.

General things to look for:

- If the system is losing pressure either during testing and/or after the system has been filled, but the flooring has not been laid, simple visual/manual checks around the manifold and along each loop of pipe should identify the problem area.
- If there are no clear visual signs, each loop/circuit may require a separate pressure test to identify the exact location.
- If the floor has been laid, identification of the fault can be traced through signs of a wet patch around the leak. Obviously to make the repair, the floor will have to be raised. In screed floors, excavate carefully in the centre of the wet patch.
- Any leaks on the manifold are generally due to the connection and any loose nuts and unions will require tightening.

Repairs.

To make a repair to the pipe, follow the processes below;

Repairing the pipe:

- Isolate the damaged pipe loop at the manifold.
- Cut out the damaged section of pipe.
- Prepare both ends of pipe using the pipe cutter. For MLC pipe use a bevelling tool.
- On panel systems, remove a small section of the floating panel or fixed tracked panel, to accommodate the compression fittings.
- Slide the compression adaptor nut over each end of pipe, together with olive on PEX pipes, prior to inserting the insert/sleeve into each end.
- Offer both ends of pipe/inserts to the compression coupler and tighten both nuts.
- Ideally, the joint will require an inspection chamber in case further maintenance is required. However, in practice this is often not practical, and the fitting is wrapped in suitable tape before burying in the screed (ensure approval with the building inspector is sought prior to doing this).
- Pressure test the system again before laying the floor covering.

Items Required

- Plastic pipe cutter
- Denso tape (for solid floors)

For 16mm MLC pipe:

- 16mm MLC adaptor for 15mm compression body, 2 x product code 1013805
- 15mm copper compression coupler

For 12mm PEX pipe:

- 12mm PEX adaptors for 15mm compression coupler, 2 x product code 1013813
- 15mm copper compression coupler

For 16mm PEX pipe:

- 16mm PEX insert for 15mm compression coupler, 2 x product code 1058934
- 15mm copper compression coupler

For 20mm PEX pipes:

- Eurocone compression adaptor 20mm PEX x 3/4" FT, 2 x product code 1010629
- 3/4" compression coupling, 1 x product code 1006641

Notes

A series of horizontal dotted lines for taking notes.

Uponor

Uponor Limited
The Pavilion
Blackmoor Lane
Watford
Hertfordshire
WD18 8GA

T 01923 927000
F 01923 223760
E enquiries.uk@uponor.com
W www.uponor.co.uk

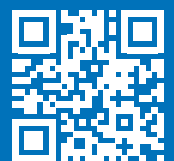

04/2016

azarnasim 
AIR CONDITIONING COMPANY

www.uponor.co.uk